

DETAIL OF PANEL SHOWING CABLE INSTALLATION

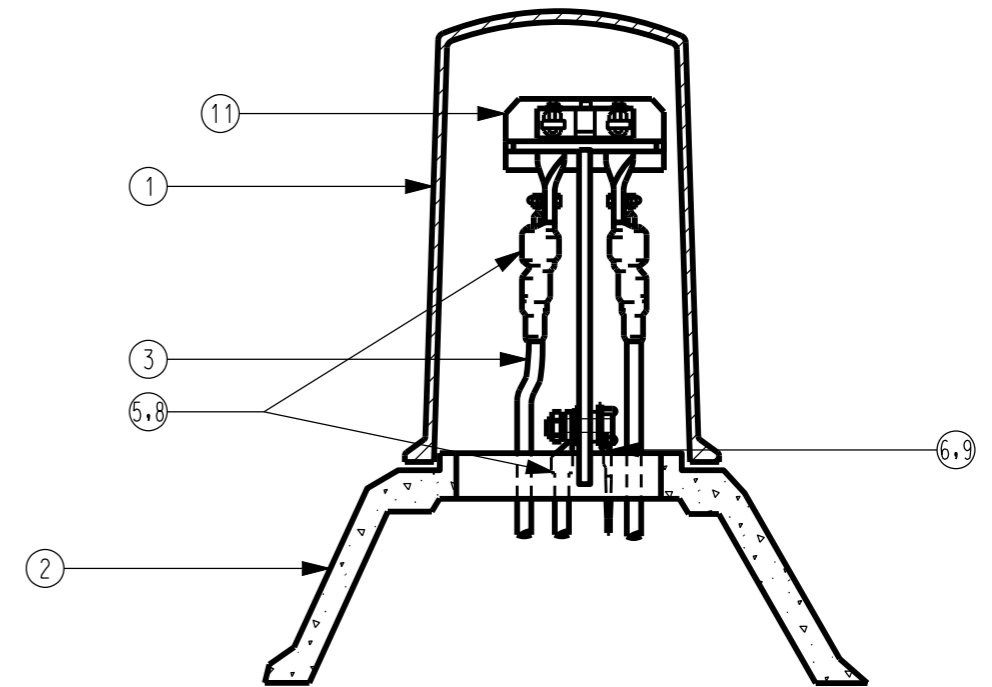

**SECTIONAL VIEW OF PILLAR
SHOWING INSTALLED CABLES**

NOTES:

1. PHASE SEQUENCE RED, WHITE, BLUE WITH RED PHASE CLOSEST TO THE ROAD.
2. FOR DEATILS OF LINK PANEL SEE DRG No. S2-1-3-4.
3. FOR DETAILS OF HEATSHRINK INSTALLATION SEE DRG No. S2-2-2-10.
4. FOR DETAILS OF DISTRIBUTION PILLAR SEE DRG No. S2-1-3-1.

| | | | | |
|------------|-----|---------|---------------------------------------------------|-----------|
| 10892 | 12 | 3 | LV LINK PILLAR URD | S2-2-3-4 |
| 3491 | 11 | 1 | PANEL - LINK DISTRIBUTION PILLAR | S2-1-3-4 |
| 9837 | 10 | AS REQ. | EARTH CONDUIT-Cu 25x3mm | S1-1-5-4 |
| 4408 | 9 | AS REQ. | SLEEVE-HEATSHRINK, BLACK | S2-1-2-15 |
| 3210 | 8 | AS REQ. | SLEEVE-HEATSHRINK, BLACK | S2-1-2-15 |
| 4184 | 7 | AS REQ. | TUBING-HEATSHRINK, PHASE COLOUR I.O. | S2-1-2-15 |
| 5215 | 6 | AS REQ. | LUG BI-METAL COMPRESSION 25mm ² | .. |
| 5280 | 5 | 8 | LUG BI-METAL COMPRESSION 185mm ² | .. |
| 9340 | 4 | AS REQ. | CABLE - SERVICE XLPE-25mm | .. |
| 9316 | 3 | AS REQ. | CABLE - MAIN - XLPE - 185mm | S2-1-1-19 |
| 3533 | 2 | 1 | BASE CONCRETE | S2-1-3-1 |
| 3582 | 1 | 1 | COVER HEAVY WALLED FIRE RESIST POLYETHELENE GREEN | S2-1-3-1 |
| STOCK CODE | No. | QTY | DESCRIPTION | DRG No. |

| | | | | | |
|------------|------------------------------------------------------------|------|---------|------|------|
| 6 | PHASING REFERED TO THE ROAD | C.M. | OCT'10 | A.T. | S.C. |
| 5 | SUPERSEDED BY S02-2-3-08 | J.C. | MAY'09 | B.C. | S.C. |
| 4 | ITEM 9 STOCK CODE REPLACED, ITEM 9 & 1 DESCRIPTION CHANGED | K.I. | FEB '05 | R.C. | C.C. |
| 3 | GENERAL REVISION TITLE & DWG No. CHANGED | G.M. | JUN '88 | .. | .. |
| NO | DESCRIPTION | DRN | DATE | CKD | APPD |
| AMENDMENTS | | | | | |

PowerWater

| | | | | | |
|-------------------------------|------------|-------------------------------------------------------------------------------|----------------|------------|--|
| DES | J HASSANEN | POWER STANDARD DRAWING | | | |
| DRN | ... | DISTRIBUTION PILLARS RESIDENTIAL LINK TYPE GENERAL ARRANGEMENT | | | |
| CKD | ... | | | | |
| APPD | ... | | | | |
| SCALE | NTS | | | | |
| ISSUED | FEB '86 | A3 | DRAWING NUMBER | S02-2-3-03 | |
| ALL DIM. IN | mm | CAD PRODUCT - DO NOT AMEND MANUALLY | | | |
| DRAFTING STANDARD TO A.S.1100 | | | | | |