

3RD ANGLE — DO NOT SCALE — REPORT ANY ERRORS, OMISSIONS TO DRAFTING OFFICE

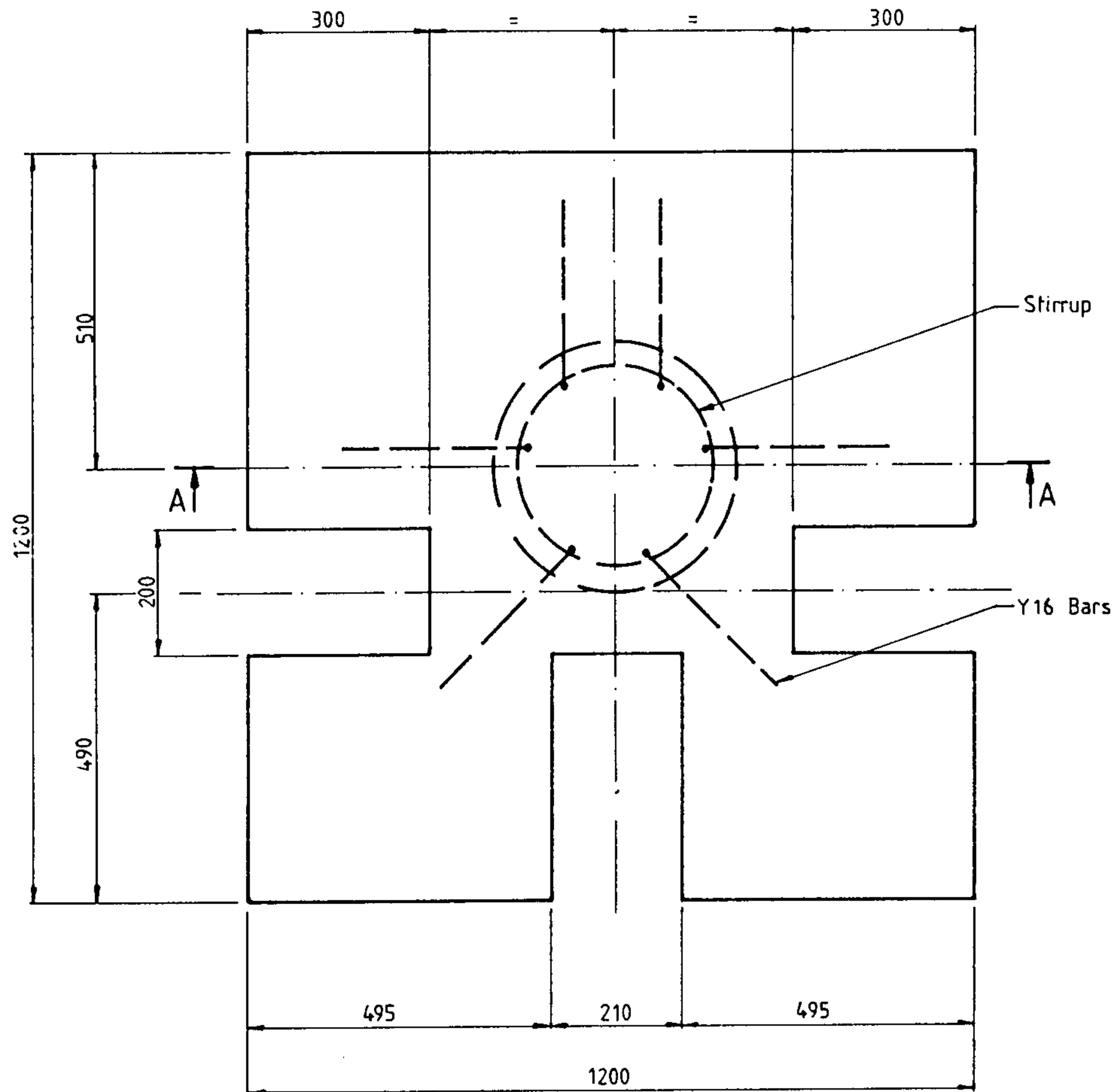

PLAN VIEW
(Mesh not shown.)

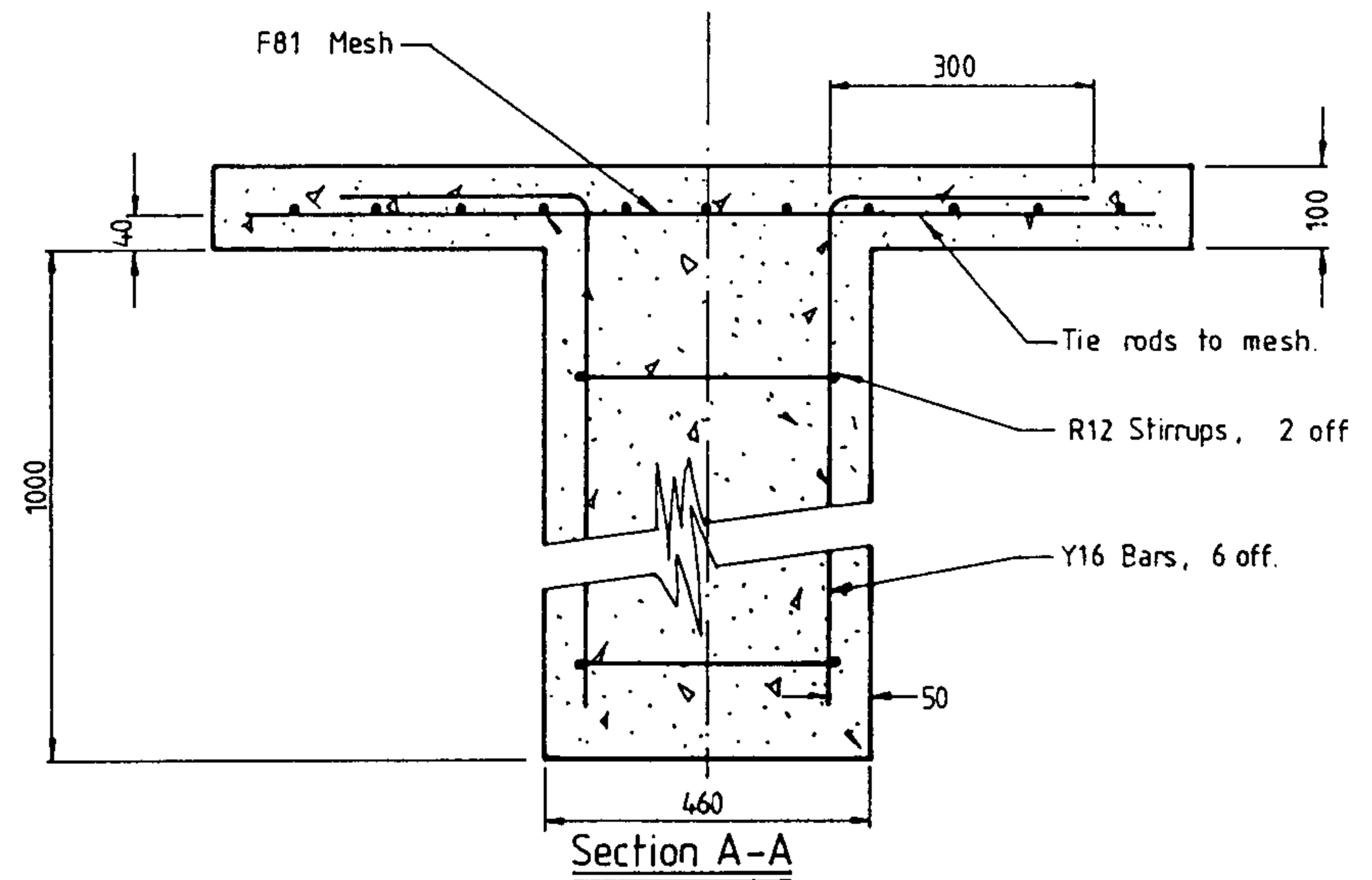

NOTES :

1. Reinforcement specification: Mesh - F81 to AS1304
Bars - to AS1302
2. Concrete to be 20 MPa at 28 days.
3. Minimum concrete cover over reinforcement to be 40 mm.
4. Unit to be fixed to foundation with suitable concrete anchoring bolts. Drill holes on site.

No.	AMENDMENT	DATE	INIT.
3	TITLE & Drg NUMBER CHANGED	6/88	GLS
2	Index number amended.	1-11-85	GM'S
1	GENERAL REVISION	1-85	T.R.

**POWER
AND
WATER
AUTHORITY**



POWER DIRECTORATE:

DES AS BUILT	NT STANDARD DRAWING	
DRN S. JACKSON	TITLE CIVIL RING MAIN UNIT LUCY FOUNDATION DETAILS	
CKD <i>K. Smith</i>	A3	DRAWING NUMBER S2-2-6-7
APPD <i>K. Smith</i>		
ISSUED 16-12-80	SCALE N.T.S.	SHEET
DRAFTING STANDARD TO A.S. 1100		AMDT.
ALL DIM. IN mm		

3