

SECTION B-B SCALE 1:5

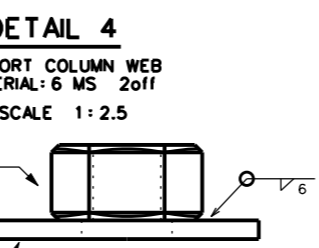

DETAIL 5 COVER NUT SCALE 1:1

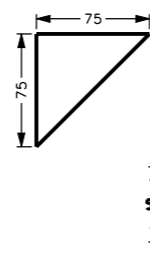
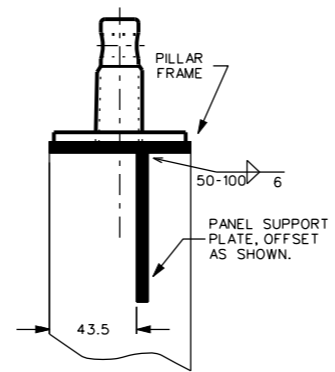

SECTION C-C SCALE 1:2

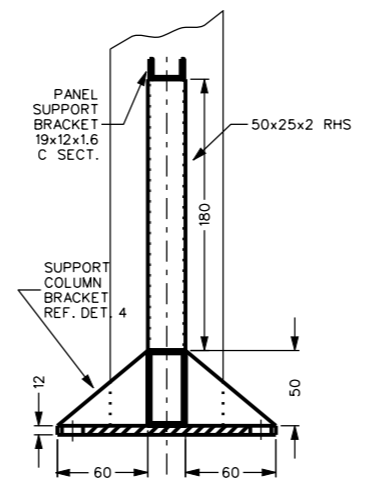

SECTION D-D SCALE 1:2.5

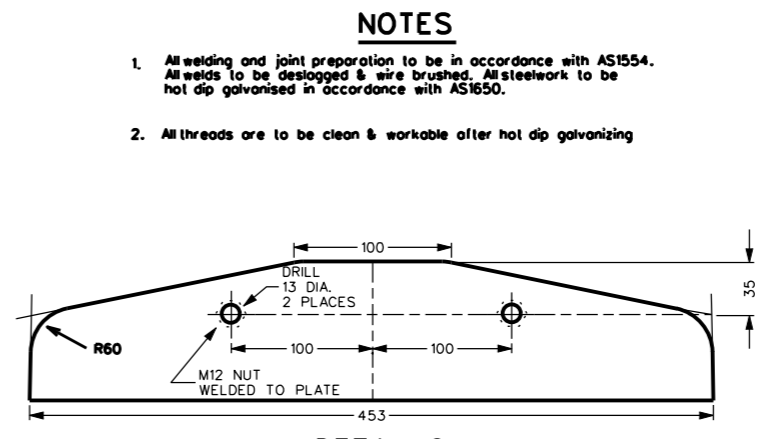

DETAIL 6 PANEL SUPPORT PLATE -75x6mm MS PLATE 1off SCALE 1:2.5

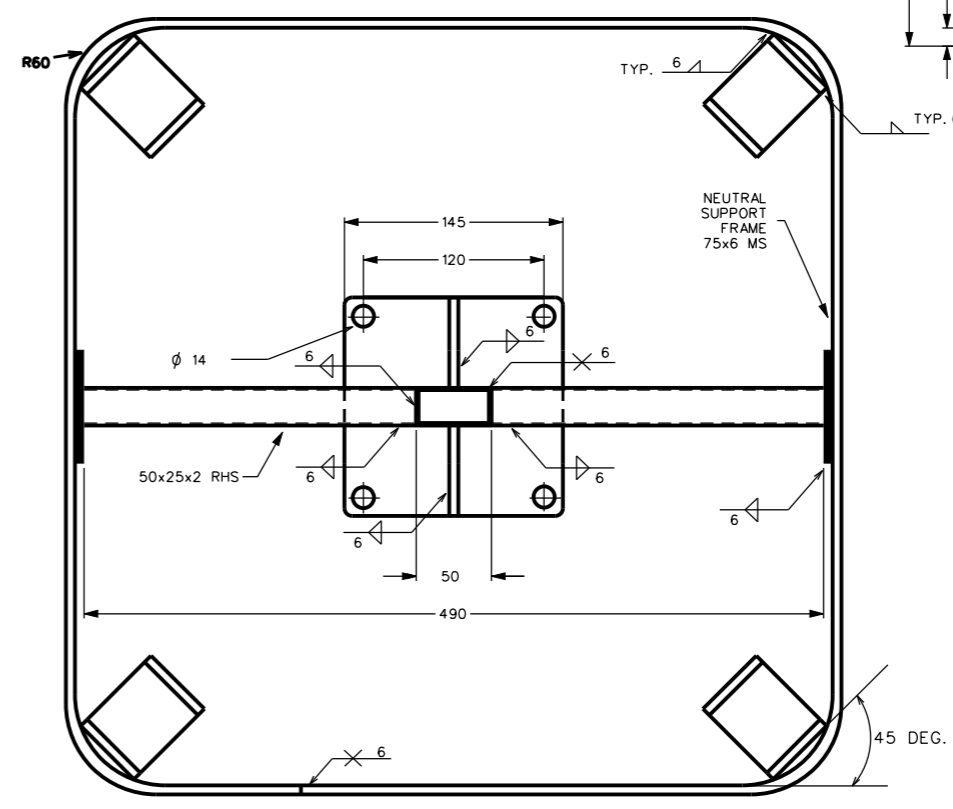

SECTION E-E SCALE 1:2.5

**NOTES**

- All welding and joint preparation to be in accordance with AS1554. All welds to be deslagged & wire brushed. All steelwork to be hot dip galvanized in accordance with AS1650.
- All threads are to be clean & workable after hot dip galvanizing

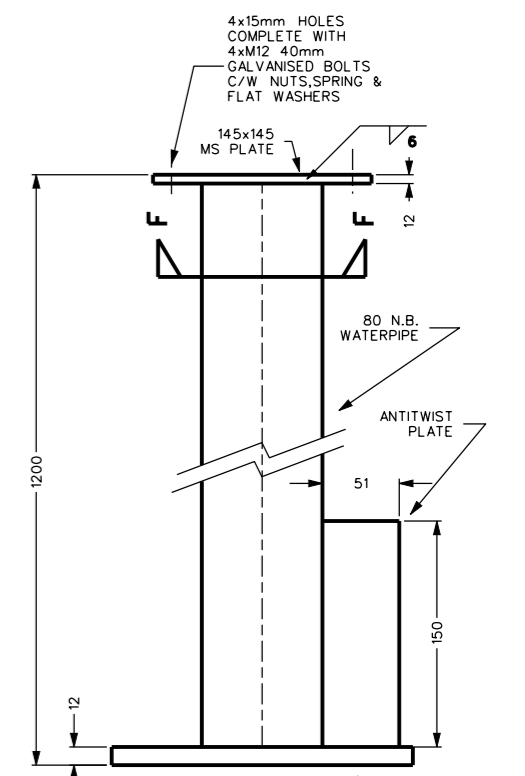

DETAIL 7 FOUNDATION SUPPORT SCALE 1:2.5

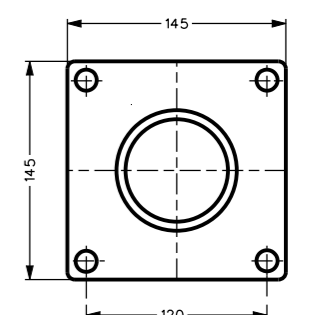

SECTION F-F SCALE 1:2.5

1	SUPERSEDED BY S02-2-3-08	J.C.	NOV'10	A.T.	S.C.
NO	DESCRIPTION	DRN	DATE	CKD	APPD
AMENDMENTS					



DES	A. WHYTE	POWER STANDARD DRAWING		
DRN	N. HORDERN	<b>FUSED DISTRIBUTION PILLAR STEELWORK ASSEMBLY AND DETAILS</b>		
CKD	S. SAWYER			
APPD	F. ROBSON			
SCALE	AS SHOWN			
ISSUED	APR'01	<b>A3</b>	<b>DRAWING NUMBER</b>	<b>S02-1-3-07</b>
ALL DIM.	IN mm			
DRAFTING STANDARD TO A.S.1100		CAD PRODUCT - DO NOT AMEND MANUALLY		<b>1</b> AMDT