

1. OVERLAP PILC AND XLPE CABLES 300mm.  
 PILC CABLE - REMOVE OUTER SHEATH, AND BRASS TAPES TO THE DIMENSIONS SHOWN. XLPE CABLES - REMOVE OUTER PVC, NYLON AND INNER HDPE SHEATHS TO THE DIMENSIONS SHOWN. MARK CENTRE OF OVERLAP AS A REFERENCE LINE AND COVER CABLES WITH PLASTIC WRAP.

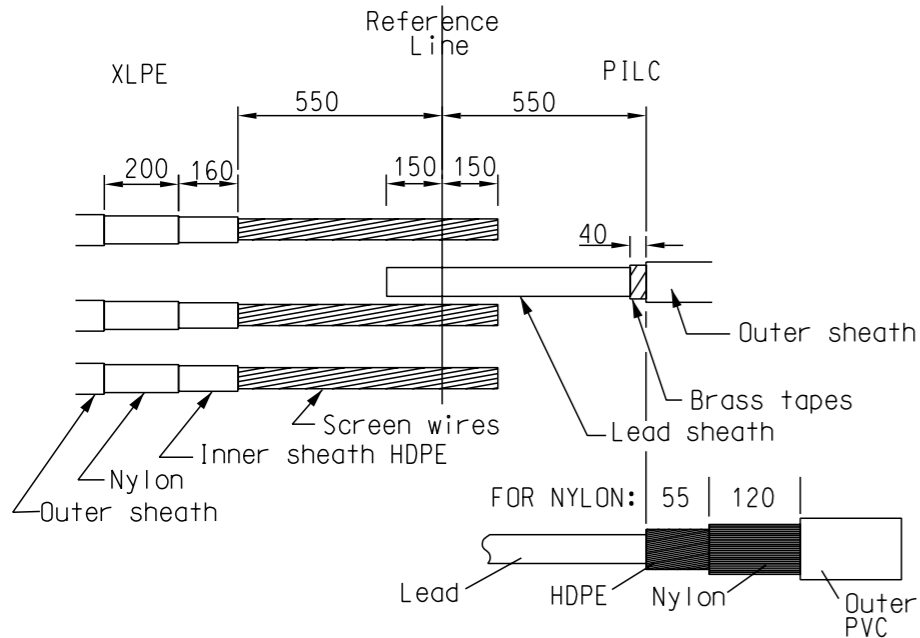

2. PILC CABLE - CLEAN LEAD SHEATH AND BRASS TAPES. POSITION 3 EARTH BRAIDS AS SHOWN AND BIND TO LEAD SHEATH AND BRASS TAPES WITH COPPER WIRE. SOLDER TO LEAD SHEATH AND BRASS TAPES. PLUMB BRAIDS TO LEAD SHEATH. DO NOT OVERHEAT THE LEAD SHEATH. FOLD BRAIDS BACK ALONG CABLE AND TEMPORARILY TAPE IN POSITION.

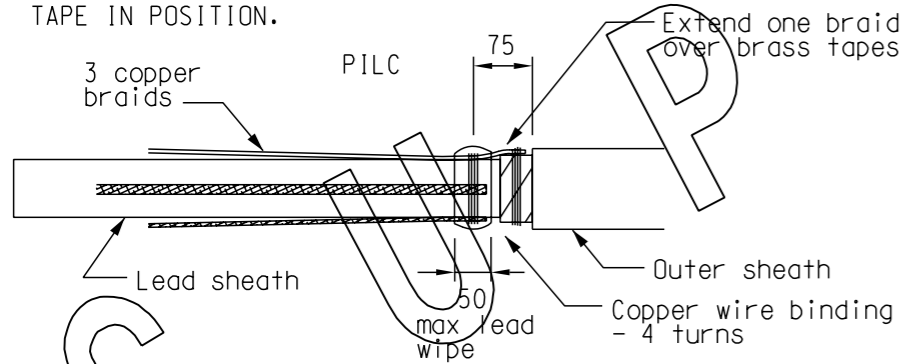

PAWA Cables: 11kV 300sq.mm Al PILC S02-01-01-2  
 11kV 240sq.mm Al XLPE S02-01-01-06

3. PILC - REMOVE LEAD SHEATH TO DIMENSION 'A'. DO NOT DAMAGE THE UNDERLYING SCREEN PAPERS ON THE CORES. UNWIND THE COPPER WOVEN FABRIC (CWF) TAPE, REMOVE FILLERS FROM BETWEEN CORES. REWIND THE CWF TAPE AROUND THE CORES AT THE CRUTCH TO THE DIMENSION SHOWN AND TIE OFF. TIE A TWINE BINDER AROUND THE SCREEN PAPERS TO DIMENSION 'S'. REMOVE SCREEN PAPERS BY UNWINDING AND TEARING CAREFULLY AGAINST THE BINDER. BIND THE INSULATING PAPERS AT THE ENDS OF THE CORES WITH A FEW TURNS OF TWINE.

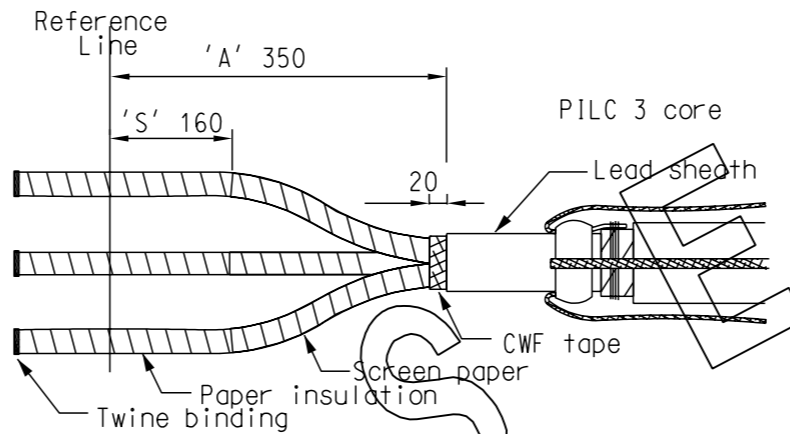

4. PILC - CUT A 50mm PIECE FROM THE STRESS CONTROL MASTIC, REFER DETAIL. PLACE THE POINT OF THE MASTIC AT THE EDGE OF THE SCREEN PAPER ON ONE OF THE CORES. TENSION THE MASTIC TO HALF ITS ORIGINAL WIDTH WHILE APPLYING 4-5 TURNS, OVERLAPPING THE SCREEN AND INSULATION PAPERS BY 10mm. REPEAT ON REMAINING CORES.

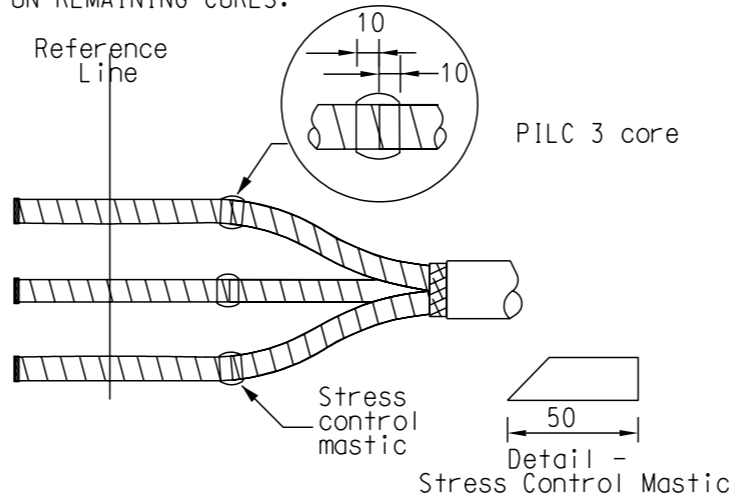

5. PILC - SLIDE THE CLEAR INSULATING TUBINGS OVER THE CORES PUSHING THEM AS FAR INTO THE CRUTCH AS POSSIBLE. SHRINK DOWN EVENLY STARTING AT THE CRUTCH AND WORKING TOWARDS THE CORE ENDS. ENSURE THERE ARE NO POCKETS OF TRAPPED AIR OR GREASE. BEFORE BENDING OR SETTING THE CORES PROTECT THE CRUTCH WITH COTTON TAPE (WHICH IS REMOVED AFTER STEP 14).

CAREFULLY MARK THE REFERENCE LINE ON THE CORES. TEMPORARILY PROTECT THE PREPARED CORES FROM DIRT WITH PLASTIC WRAP.

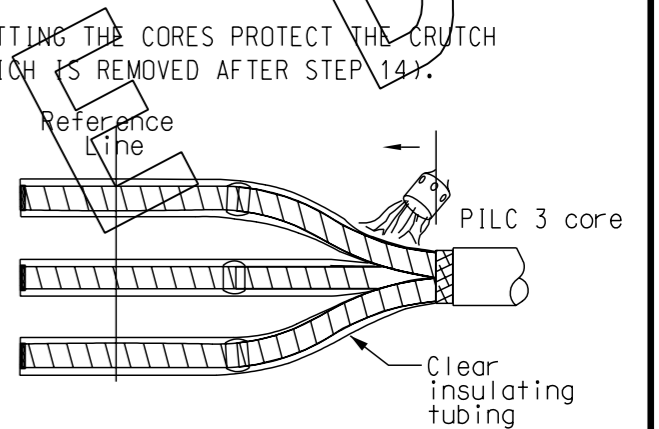

6. XLPE CABLES - CLEAN, DEGREASE AND ABRABE THE INNER SHEATH. REMOVE THE RELEASE PAPER FROM THE RED SEALANT MASTIC STRIP AND WRAP ONE LAYER AROUND THE SHEATH (100mm). APPLY MASTIC WITH SLIGHT TENSION AND A SMALL OVERLAP.

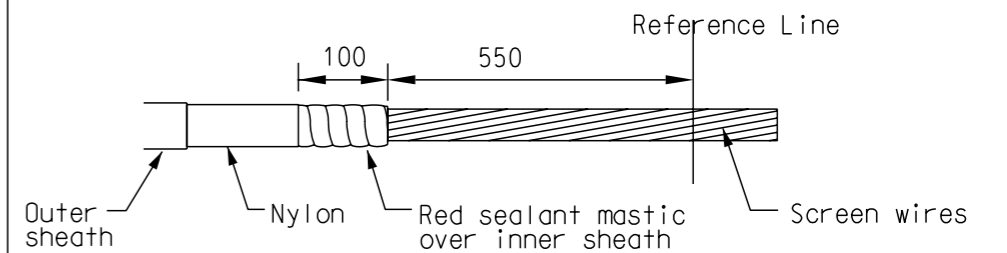

7. XLPE - UNWIND THE SCREEN WIRES AND LAY THEM BACK OVER THE SHEATH. SPREAD THEM EVENLY AROUND THE CABLE, BEDDING THEM INTO THE RED SEALANT MASTIC. TEMPORARILY BIND THE WIRES WITH PVC TAPE. PROTECT FROM DIRT WITH PLASTIC WRAP.

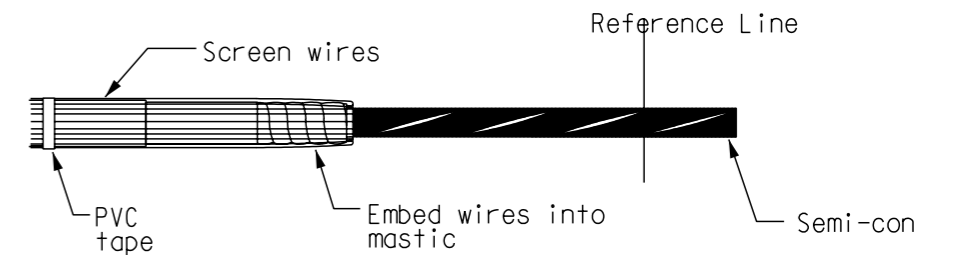

Raychem kit EFSJ-11-D-T4

NO	DESCRIPTION	DRN	DATE	CKD	APPD
1	SUPERSEDED	A.T.	DEC'12	B.C.	B.C.
AMENDMENTS					

**PowerWater**  
 NORTHERN TERRITORY

DES	JEH/ICV 10/96	POWER STANDARD DRAWING			
DRN	R. INNES	<b>CABLE JOINTING &amp; TERMINATIONS</b> <b>RAYCHEM JOINTING INSTRUCTIONS</b> <b>11kV 3C 300sq.mm SCREENED PILC</b> <b>TO 11kV 3x1C 240sq.mm XLPE</b>			
CKD	-				
APPD	F. ROBSON				
SCALE	NO SCALE				
ISSUED	MAY'98				
ALL DIM. IN mm		A3	DRAWING NUMBER	S02-02-02-27	 AMDT
DRAFTING STANDARD TO A.S.1100		CAD PRODUCT - DO NOT AMEND MANUALLY			