

Water Supply and Sewerage Approved Products Manual - February 2006

Water Supply – Surface and Subsurface Accessories

Section WO 03

SPECIFICATIONS		A	
	WO 03-S1	SURFACE BOXES FOR UNDERGROUND HYDRANTS	A
	WO 03-S2	PITS FOR UNDERGROUND HYDRANTS	B
	WO 03-S3	SURFACE BOXES FOR UNDERGROUND STOP VALVES	C
	WO 03-S4	STANDPIPES FOR UNDERGROUND HYDRANTS	D
	WO 03-S5	KEY FOR UNDERGROUND HYDRANTS AND STOP VALVES	E
	WO 03-S6	MARKER POSTS FOR UNDERGROUND MAINS AND STOP VALVES	F
	WO 03-S7	MARKER POSTS FOR UNDERGROUND HYDRANTS	G
	WO 03-S8	MARKING PAINT FOR KERB MARKINGS AND SURFACE BOX TOPS	H
	WO 03-S9	RETROREFLECTIVE ROAD PAVEMENT MARKERS FOR HYDRANTS	I
	WO 03-S10	MARKING TAPE FOR UNDERGROUND MAINS	K
	WO 03-S11	KERB MARKER DISCS	L
VALVE ACCESSORIES		1	
	SURFACE BOXES FOR STOP VALVES	1	
	SURFACE BOXES FOR HYDRANTS	1	
	PITS FOR HYDRANTS	1	
	STANDPIPES FOR HYDRANTS	2	
	KEY FOR HYDRANT/STOP VALVE	2	
MARKERS		3	
	MARKER POSTS FOR UNDERGROUND MAINS AND STOP VALVES	3	
	MARKER POSTS FOR HYDRANTS	3	
	MARKING PAINT FOR KERB MARKINGS AND SURFACE BOX TOPS	3	
	PAVEMENT MARKERS FOR HYDRANTS	3	
	MARKING TAPE FOR UNDERGROUND MAINS	3	
	KERB MARKER DISCS	4	

WO 03-S1 SURFACE BOXES FOR UNDERGROUND HYDRANTS

STANDARD BS 750:2006 Underground fire hydrants and surface box frames and covers (hydrant box)

DRAWING **Power and Water:** W1-2-03A (installation off DN100-300)
W1-2-03B (installation off DN 375-750)
W1-2-03F (location)

DESIGN Rectangular cast iron surface boxes comprise a frame and an adjoining hinged cover and are to be supplied as a complete unit. Cast units are to be cleanly cast and free from air holes, sand holes, cold shuts and chill. Cast units are to be neatly dressed and carefully fettled. Surface of cover is to be finished with a non skid pattern raised 5 mm. Top of cover is to be flush with the top of the frame. The cover is to include a key hole and prising bar recess for raising the cover.

For roadways, (vehicular) surface boxes shall be of strength Grade A to BS 750, capable of carrying an ultimate load of 300 kN.

For non-vehicular areas (footpaths or verges), surface boxes shall be of strength Grade B to BS 750, capable of carrying an ultimate load of 125 kN.

MATERIALS **Cover & frame:** Ductile cast iron grade AS 1831/700-2, 600-3, 500-7, 450-10, 400-15, 400-18 or 350-22
Grey cast iron grade AS 1830/150, 200 or 250
Hinge spindle: Carbon steel grade AS/NZS 1111/4.6
Coating: Bitumen to AS/NZS 3750.4

DIMENSIONS Vehicular and non-vehicular

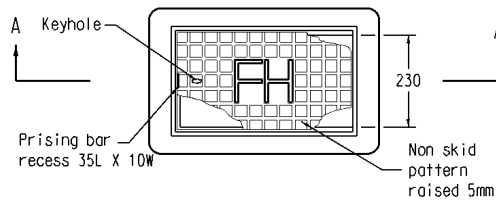

Plan

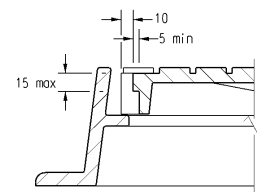

Prising bar recess detail

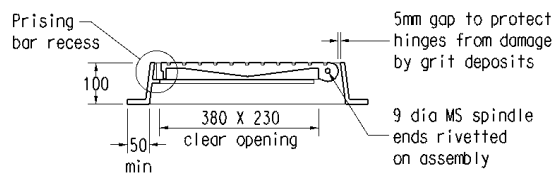

Section A-A

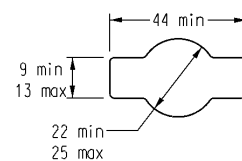

Keyhole

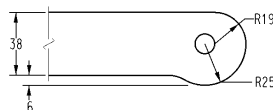

Cover Hinge detail

MARKINGS "FH" in capital letters cast-in to the centre of the cover with minimum lettering height of 75 mm. Marking with "BS 750:2006 GRADE A – Vehicular" is optional for vehicular rated surface boxes. Marking on the underside of the cover to indicate the opening direction of the hydrant is optional.

WO 03-S2 PITS FOR UNDERGROUND HYDRANTS

STANDARD	None
DRAWING	PowerWater: W1-2-03A (installation off DN100-300) WSA 03: WAT-1302 W1-2-03B (installation off DN 375-750)
DESIGN	<p>Rectangular pits to house the hydrant are to have a top apron of compatible dimensions to the hydrant surface box base apron. Pits are to be of depth and width to provide sufficient clearance about the BS 750 underground hydrant. Pits are to resist fracture and excessive distortion (more than 5mm) from:</p> <ul style="list-style-type: none"> • wheel loads applied through the surface box (up to 5 tonnes from fast moving normal commercial vehicles; up to 11.5 tonnes from slow moving specially authorised vehicles) • external soil and hydrostatic loadings • mechanical compaction of external soil during installation and backfill <p>Pits are to resist degradation from moisture and corrosive soils/groundwater/surface water.</p>
MATERIALS	<p>Glass reinforced plastic (GRP) of composition as approved Polyethylene to AS/NZS 4131 or as approved Other materials approved by Power and Water</p>
DIMENSIONS	<p>Inside apron top: B x D (current approved design uses 455 mm x 245 mm) Outside apron top: A x C (current approved design uses 575 mm x 365 mm) Base : 385 mm x 190 mm minimum Depth: 400 mm Wall thickness: As required to achieve sufficient strength to resist fracture and excessive distortion</p>

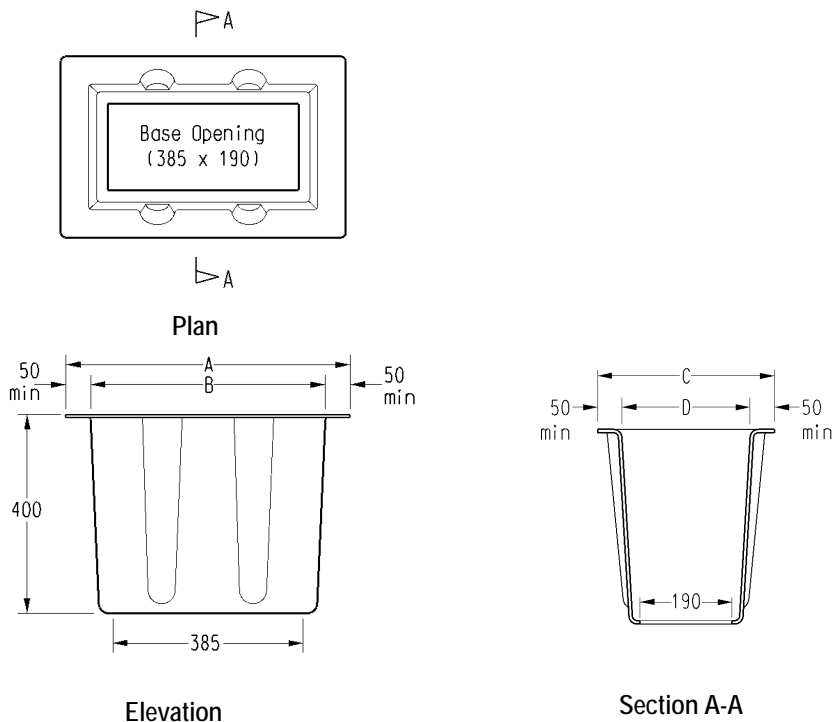

WO 03-S3 SURFACE BOXES FOR UNDERGROUND STOP VALVES

STANDARD None

DRAWING Power and Water: W1-2-03B

DESIGN Rectangular cast iron surface boxes comprise a frame and an adjoined hinged cover and are to be supplied as a complete unit. Surface boxes are to be suitable for their intended application as follows:

- Vehicular – Areas expected to be accessible to fast moving heavy motor vehicles including carriageways of roads and driveways. Capable of carrying an ultimate load of 300 kN
- Non-vehicular:- Areas not generally accessible to fast moving heavy motor vehicles including footpaths and verges. Capable of carrying an ultimate load of 125 kN.

Cast units are to be cleanly cast and free from air holes, sand holes, cold shuts and chill. Cast units are to be neatly dressed and carefully fettled. Surface of cover for non-vehicular applications is to be finished with a non-skid pattern raised 5 mm. Top of cover is to be flush with the top of the frame. The cover is to include a prising bar recess for raising the cover.

MATERIALS

Cover & frame: Ductile cast iron grade AS 1831/700-2, 600-3, 500-7, 450-10, 400-15, 400-18 or 350-22
 Grey cast iron grade AS 1830/150, 200, or 250

Hinge spindle: Carbon steel grade AS 1111/4.6

Coating: Bitumen to AS/NZS 3750.4

TYPE TESTING

Test apparatus generally in accordance with Clause C3 of AS 3996-2006
 Test to ultimate load of 300 kN or 125 kN as applicable. No load reduction factor applicable.
 Test surface box using a 240 mm x 240 mm test block placed centrally on top of frame.
 For surface boxes with dimensions as per non-vehicular surface boxes, also test using a 150 mm x 240 mm test block placed centrally on top of lid, such that load applied directly to lid
 Type test report generally in accordance with Clause C5.2 of AS 3996-2006

DIMENSIONS

Non-vehicular: Functionally large enough to allow insertion of valve key and replacement of valve (i.e. to AS 2638) stem sealing 'O' rings.

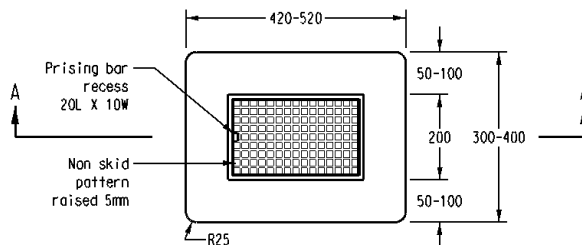

Plan

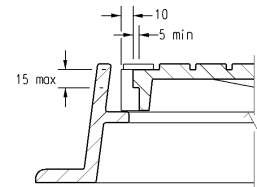

Prising bar recess detail

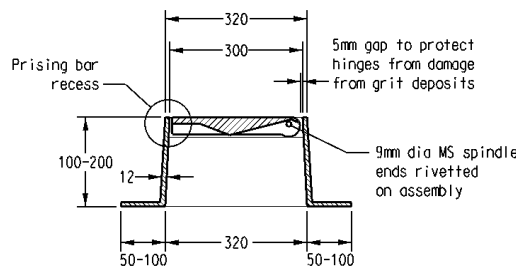

Section A-A

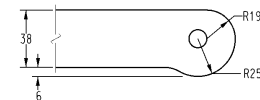

Cover hinge detail

Vehicular: Functionally large enough to allow insertion of valve key. Preferably, dimensions same as non-vehicular above

MARKING "SV" in capital letters cast-in centre of cover with preferred lettering height of 75 mm (optional).

WO 03-S4 STANDPIPES FOR UNDERGROUND HYDRANTS

STANDARD	BS 336:1989	Fire hose couplings and ancillary equipment
DESIGN	The standpipe is used for connecting a fire hose to an underground hydrant. It comprises a socketed end at the base suitable to connect to a BS 750 fire hydrant and a threaded spigot end at the top to connect to a fire hose socket. When machining the base, the leading and trailing edge feathers are to be cut back to two thirds the thread thickness. The standpipe is to have sufficient resistance to damage and permanent deflection.	
MATERIALS	Shaft tube:	Galvanised steel (medium) to AS 1074 Copper grade BS 2871/C106 or equivalent Aluminium alloy grade BS 1474/6082T6 or BS 1471/6082TF
	Base and head:	Copper alloy grade BS 1400/LG2 or equivalent Aluminium alloy grade BS 1490/LM16TF or LM25TF or equivalent
	Base washer:	Natural rubber to BS 1154 (grade Z70) or equivalent
DIMENSIONS	Height:	750 mm approximately from bottom of base to top of head
	Shaft diameter:	DN 64 (approximately 64 mm external diameter)

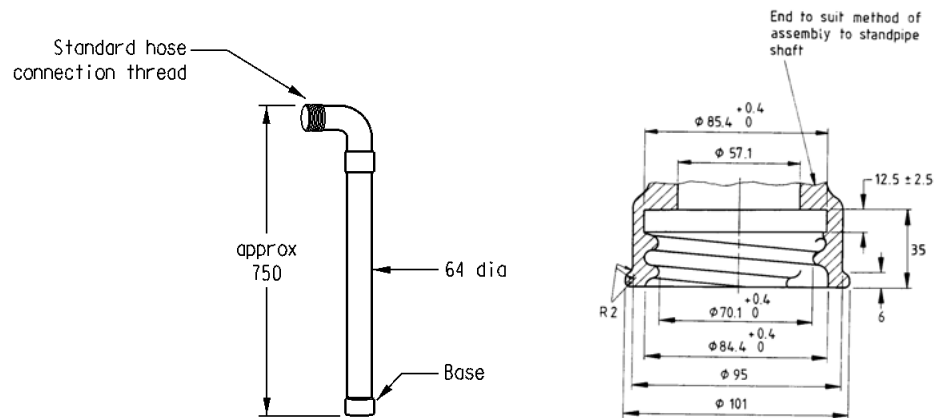

Standpipe

Standpipe base

CONNECTION	Head:	Standard hose connection –screwed end of 65 mm diameter with external Whitworth form Vee thread to 5.08 mm pitch in accordance with NT Fire Services specification.
	Base:	To BS 336 as shown above
MARKING	Manufacturer's name or trademark Year of manufacture BS 336 : 1989 (alternatively show conformance to BS 336 on certificate, packaging or literature)	
MARKING METHOD	Legible and permanent marking	

WO 03-S5 KEY FOR UNDERGROUND HYDRANTS AND STOP VALVES

STANDARD	BS 336:1989 Fire hose couplings and ancillary equipment
DESIGN	Keys are used to operate underground BS 750 screw down hydrants and AS 2638 sluice valves. The key comprises a shaft with an attached flared key end incorporating a recess of shape to mate with the valve stem cap. Near the top of the shaft is a hole to fit a removable bar. The bar is used as a handhold to rotate the key. The key is to resist damage or permanent deformation.
MATERIALS	<p>Shaft tube: Aluminium alloy grade BS 1474/6082T6 or BS 1471/6082TF or BS1490/LM16TF or BS1490/LM25TF or equivalents Stainless steel grade BS970:Part 4/321 S22 or BS970/321 S20 or equivalents Steel grade BS 6323: Part 1/CD S2 or equivalent</p> <p>Key end: Aluminium alloy grade BS 1474/6082T6 or BS 1471/6082TF or BS1490/LM16TF or BS1490/LM25TF or equivalents Stainless steel grade BS970:Part 4/18/8 Cr, casting or equivalent Malleable iron casting to BS 6681 or equivalent</p> <p>Handhold bar: Aluminium alloy grade BS 1474/6082T6 or BS 1471/6082TF or BS1490/LM16TF or BS1490/LM25TF or equivalents Stainless steel grade BS970:Part 4/431 S29 or equivalent Steel grade BS970:Part 4/605 M36 condition T or equivalent</p>
DIMENSIONS	<p>Key length: Sufficient to allow the handhold to clear the adjacent standpipe or other obstructions.</p> <p>Shaft tube: 35 mm internal diameter</p> <p>Key end: In accordance with AS 2638.1 figure 3.2 – the recess x-section is 35 mm square at 50 mm along its depth.</p> <p>Handhold bar: 20 mm minimum external diameter and 450 mm minimum long</p>

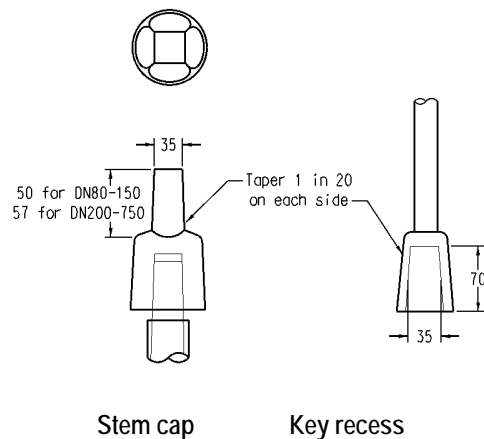
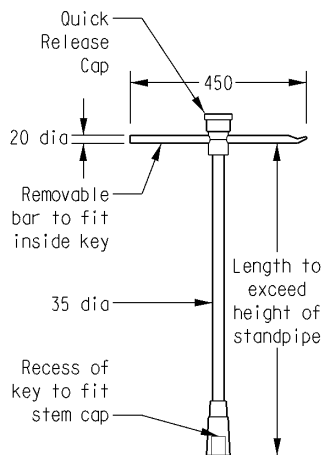

MARKING	<p>Manufacturer's name or trademark</p> <p>Year of manufacture</p> <p>BS 336 : 1989 (alternatively show conformance to BS 336 on certificate, packaging or literature)</p>
MARKING METHOD	Legible and permanent marking

WO 03-S6 MARKER POSTS FOR UNDERGROUND MAINS AND STOP VALVES

DRAWING	Power and Water: W1-2-03D, W1-2-03H	WSA 03: WAT-1300
DESIGN	Post with cap and marker plate attached near the top of the post displaying lettering to suit service to be identified. Letters are to be screen printed onto a self adhesive retroreflective label. Post profile to be as approved to satisfy strength, label visibility and label adherence requirements.	
MATERIALS	<p>Post and cap: 75 x 75 x 4 square hollow section (grade 350 or higher) to AS 1163, hot dip galvanised after fabrication (minimum 300g/m² on each surface). Galvanised steel cap to suit post. After fitting of cap to post, coat with polymeric powder coating (60 microns minimum) to AS/NZS 4506 Other materials as approved</p> <p>Marker plate: Aluminium plate to AS/NZS 1734 e.g. 5005-H34 Other materials as approved</p> <p>Marker plate label: Self adhesive retroreflective sheeting class 1 to AS 1906.1 (e.g. 3M Scotchlite High Intensity Reflective Sheeting Series 3870)</p> <p>Letters: Ink compatible with retroreflective sheet (Scotchlite Series 880 Process Colours)</p>	
COLOURS	<p>Mains post/cap: White, code N14 to AS 2700 or near equivalent</p> <p>Stop valve post/cap: Signal Red, code R13 to AS 2700 or near equivalent</p> <p>Marker plate label: White, code N14 to AS 2700 or near equivalent (e.g. 3M White 3870)</p> <p>Letters: Reflectorised Signal Red, code R13 to AS 2700 or near equivalent (e.g. 3M Traffic Signal Red 882)</p>	
DIMENSIONS	<p>Post length: 1320 mm long (750 mm above finished surface level when installed)</p> <p>Marker plate: 250 mm high x 75 mm wide x 2 mm thick with <u>rounded corners</u></p> <p>Letters: 80 mm high x 35 mm wide with 10 mm thick strokes</p> <p>Marker plate label:</p>	
MARKER PLATE LETTERS	<p>Water reticulation main: WM (one on top of the other)</p> <p>Water rising main: RM (one on top of the other)</p> <p>Stop valve: SV (one on top of the other)</p>	
MARKER PLATE FIXING	Top of plate, 150 mm below the underside of post caps. Plate attached at points clear of lettering using rivets or screws of around 5 mm diameter, with no less than 2 mm protrusion.	
USE LIMITS	<p>Mains Install along the pipe centreline at 100 m maximum intervals and at all changes of direction where specified in project documentation. Do not use in Aboriginal communities. Normally not used in developed areas.</p> <p>Stop valves: Use only where there is no kerb for marking or where directed when the valve is not easily located from the kerb marking. Do not use in Aboriginal communities. Normally not used in developed areas.</p>	

WO 03-S7 MARKER POSTS FOR UNDERGROUND HYDRANTS

DRAWING	Power and Water: W1-2-03F (installation & location) WSA 03: WAT-1300
DESIGN	Post with self adhesive label attached near top of post and having the capital letter "H", screen printed with black vinyl ink. Post profile is to allow the retroreflective label to be displayed flat to maximise adhesion and angular visibility. Post is to be of profile to satisfy appropriate strength requirements. Base of post is to be of shape to minimise driving force into ground.
MATERIALS	<p>Post: GRP with marble reinforcing mat of continuous E glass rovings. Resin to contain UV stabilisers Galvanised steel (medium) to AS 1074 with polymeric powder coating (60 microns minimum) Thermoplastic amorphous recycled PET Other materials as approved</p> <p>Label: Self adhesive retroreflective sheeting class 1 to AS 1906.1 (e.g. 3M Scotchlite High Intensity Reflective Sheeting Series 3870)</p> <p>"H": Ink compatible with retroreflective sheeting (e.g. Scotchlite Series 880 Process Colours)</p>
COLOURS	<p>Post: White, code N14 to AS 2700 or near equivalent</p> <p>Label: Golden Yellow, code Y14 to AS 2700 or near equivalent (e.g. 3M Yellow 3871).</p> <p>"H": Black (e.g. 3M Black – Opaque 885)</p>
DIMENSIONS	<p>Post length in poorly maintained verges: 1800 mm long (1200 mm above finished surface level when installed)</p> <p>Post length in all other areas: 800 mm long (500 mm above finished surface level when installed)</p> <p>Label:</p>

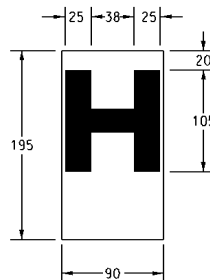

USE LIMITS	<p>Residential: Use two marking methods; marking methods of kerb engraving and retroreflective road marker are preferred to marker post.</p> <p>Industrial/Commercial: Install wherever possible. As an alternative to a marker post, an adhesive retroreflective label on a metal plate fixed to a building or permanent surface may be used where approved by Power and Water.</p> <p>Use manufacturer's post driver and support to install. Where not appropriate for post to be driven in, provide a concrete foundation to full depth of post (300 mm except in poorly maintained verges where it is 600 mm) and 80 mm minimum width all round the post.</p>
-------------------	---

WO 03-S8 MARKING PAINT FOR KERB MARKINGS AND SURFACE BOX TOPS

STANDARD	AS 3730.10-1992 Guide to the properties of paints for buildings, Part 10: Latex-Exterior-Gloss
SPECIFICATION	APAS: *APAS-0280/1 Gloss Exterior Latex Paint (Buildings) – formerly specification GPC-L-28 (specification requires compliance to AS 3730.10 and additional tests) *Australian Paint Approval Scheme - supercedes Government Paint Committee
DRAWING	Power and Water: W1-2-03F and W1-2-03G WSA 03: None (not referenced on WAT-207)
DESIGN	Gloss exterior latex (acrylic) paint is to be suitable for applying to concrete in not less than two coats to a dry film thickness of typically 20-25µm per coat. Paint is to satisfy requirements for drying time, recoating defects, gloss, colour match, opacity and cracking. After weathering for 24 and 36 months, paint is to satisfy requirements for discolouration, change in gloss, checking, cracking, blistering, flaking/peeling, chalking and colour change. APAS-0280/1 additionally specifies more severe requirements for discolouration, change in gloss, chalking and colour change and requires no integrity failure after 48 months.
MATERIALS	Latex binder of polymerised organic compounds in aqueous dispersion Appropriate colouring pigments Volatiles consisting essentially of water
COLOURS	Kerb background and surface box covers: Signal red colour code R13 to AS 2700 Kerb letters: Golden yellow colour code Y14 to AS 2700
CONTAINER	Tin plate cans to AS 2854 (up to 10 L containers) or steel drums to AS 2905 (20 L and larger)
CONTAINER MARKING	The name or registered mark of the manufacturer The description 'Gloss Latex Paint for Exterior Use' or equivalent wording The contents of the container by volume, in litres or millilitres For containers of capacity one litre or greater, the production or batch number of the contents. Colour identification of the dry film, i.e. colour code details shown above Guidance on the use of the paint
CONTAINER MARKING METHOD	Legibly and durably marked on the container or on a label permanently attached to each container.
USE LIMITS FOR KERB MARKING	Residential: Use kerb engraving in preference to marker post where possible. Industrial/Commercial: Always use kerb engraving. Paint not to be applied until concrete has cured for at least nine weeks. Paint the kerb top and side fully over 500 mm, equidistant about "FH" or "SV" letters. Apply a minimum of three coats in accordance with the manufacturer's instructions.

WO 03-S9 RETROREFLECTIVE ROAD PAVEMENT MARKERS FOR HYDRANTS

STANDARD AS 1906.3:1992 Retroreflective materials and devices for road traffic control purposes – Raised pavement markers (retroreflective and non-retroreflective)

DRAWING PowerWater: W1-2-03F (location) **WSA 03: WAT-207 (incompatible)**

DESIGN Road pavement markers are to have retroreflective lenses to provide point sources of light and thus be delineable at normal night-time highway viewing distances. Reflective lenses are to be on two opposing sloping faces to allow delineation by roadway traffic in both directions. Markers are to have contrasting reflection and profile to the pavement so as to be delineable in daylight. The perceived night-time colour is to remain blue. The exterior of the marker is not to contain any sharp projections hazardous to tyres. The exterior surfaces are to be smooth with all exposed edges rounded. The top surface is to have a gloss finish and be convex. Changes in curvature are to be gradual. Markers are not to retain road grime and are to resist water ingress. Markers are to be sufficiently resistant to loss of lens luminance, loss of gloss, distortion, softening or other physical deterioration due to ambient heat. Markers are to be sufficiently resistant to loss of lens luminance, loss of impact strength and change in colour and fade due to UV exposure. Markers are to be sufficiently resistant to impact from traffic to prevent permanent damage detrimental to long term performance. Markers are to have a base flat to a tolerance of 2 mm. The base finish is to promote long term adherence to the material used to bond to the road surface. The bond strength of adhesion to the road is to be at least 2.0 MPa.

MATERIALS (not in AS 1906.3)
Marker shell: Materials as approved on submission, e.g. methyl methacrylate
Reflective lens cover: Untempered glass or other approved material
Marker filler: Resin with sufficient adherence to marker shell
Marker base: Sand or inert granules embedded in resin filler

COLOURS
Marker: Blue (transparent for where markings are to be seen through the shell)
Reflectors: Blue

DIMENSIONS
Marker base: 90 to 130 mm width x 200 mm max. length
Marker height: 10 to 20 mm
Slope of each reflecting surface: 30° approximately (not in AS 1906.3)
Area of each reflecting surface: 2100 mm² minimum (not in AS 1906.3)
Area of each glass cover for lens: 1930 mm² minimum (not in AS 1906.3)
Thickness of glass cover for lens: 0.075 mm minimum

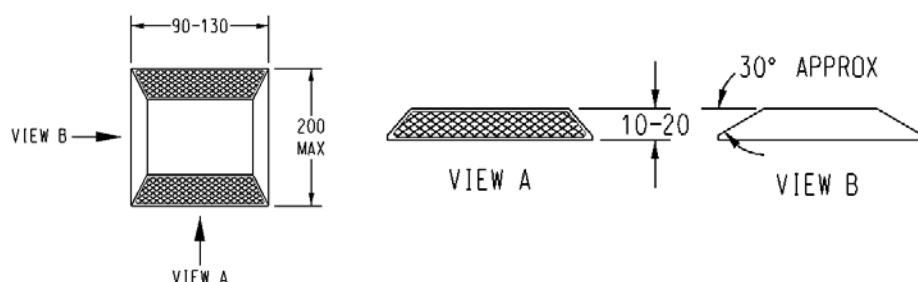

MARKER MARKING Manufacturer's name or trademark (the only requirement of AS/NZS 1906.3)
 Model number

MARKER MARKING METHOD Markings may be raised lettering on the marker surface or indelible black lettering marked on the inside surface of the transparent marker shell or the surface under the transparent shell.

PACKAGING MARKING Manufacturer's name or trademark Production batch number
 Product designation, i.e. type, size and colour Date of manufacture

USE LIMITS
Residential: Use in preference to hydrant marker post where possible.
Industrial/Commercial: Always use where roads are paved.

MARKER FIXING TO ROAD

Rigid pavement:
Sealed flexible pavement:

High strength, impact resistant epoxy, type A and B two part mix
Proprietary bituminous pad, heat bonded to pavement & marker

STEP 1



STEP 2

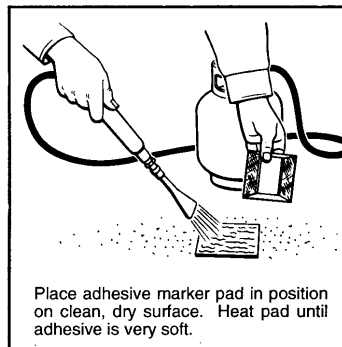

STEP 3

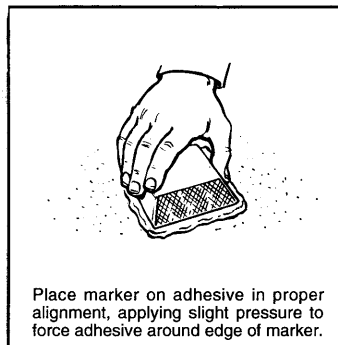

WO 03-S10 MARKING TAPE FOR UNDERGROUND MAINS

STANDARD	AS/NZS 2648.1:1995 Underground marking tape Part 1: Non detectable tape (AS/NZS 2648.1 is generally applicable to detectable tape)
DESIGN	Underground marking tape is to have sufficient toughness and elongation ability to allow mechanical diggers to pull the tape to the surface before breakage. Tape and tracer wire are to substantially resist breakage from probing equipment. On exposure to naturally occurring ground chemistry, tape is to sufficiently retain elongation ability and is to sufficiently resist discolouration and disadhesion of warning messages. Detectable tape, which incorporates a metallic strip or wire, is to be detectable at 0.3 m to 1.5 m below ground surface without connecting a signal transmitter to the wire. Means of joining tracer strip or wire in successive lengths of tape is to be provided. Tracer wire is to be affixed to the tape by placing between tape layers or other approved means. Means to increase the elongation ability of tracer wire beyond its strain capabilities is preferred, e.g. snaking of the wire along the tape.
MATERIALS	Tape: Thermoplastic Tracer strip/wire: Stainless steel grade ASTM A276/316 or equivalent Wire/strip joiners: Stainless steel grade ASTM A276/316 or equivalent
COLOUR	Green (Jade G 21 to AS 2700) for water main identification
DIMENSIONS	Width: 75 mm minimum, 100 mm and 150 mm preferred, $\pm 5\%$ tolerance Length: 100 m minimum Tracer wire: 0.7 mm minimum diameter
TAPE ELONGATION	No chemical exposure: 300% min longitudinal, 350% min transverse (to AS/NZS 4275.1) After chemical exposure: 240% min longitudinal, 280% min transverse (to AS/NZS 4275.1)
TAPE STRENGTH	Tear resistance: 3.0 N minimum longitudinal, 3.5 N minimum transverse (AS/NZS 4275.2) Impact resistance: Withstand penetration by a dart of mass 160g (+5, -0) (AS/NZS 4275.3)
DISCOLOURATION	Colour contrast to original tape to be not greater than grade 3 of grey scale (AS/NZS 4275.5) after chemical exposure (AS/NZS 4275.4).
PRINT ADHESION	Not more than 10% print removal (AS/NZS 4275.6) after chemical exposure (AS/NZS 4275.4)
WARNING MESSAGE	"CAUTION-WATER MAIN BURIED BELOW" or "DANGER-BURIED WATER MAIN BELOW"
MESSAGE MARKING METHOD	Vertical block full stroke black lettering of 25 mm minimum height. Message to be repeated at 1 m maximum intervals. Message to be centrally placed relative to the width.
ROLL FORMER	Adequate strength to allow handling and unrolling. Each roll to have a continuous length of tape (tape splices at 500 mm minimum apart are allowed). Roll internal diameter of 50 to 105 mm.
ROLL FORMER MARKINGS	Manufacturer's name or trademark Tape identification, e.g. for water mains Tape length and width Traceability code to include place of manufacture and batch number or date of manufacture
ROLL FORMER MARKING METHOD	Legible and indelible lettering of 5 mm minimum height in a visible location.
USE LIMITS	Use detectable tape only above non-metallic pipelines. Join tracer wire for successive lengths of detectable tape. Bring detectable tape to the surface at all valves to allow connection of a signal transmitter. Overlap successive lengths of non-detectable tape by at least 1 m.

WO 03-S11 KERB MARKER DISCS

STANDARD	None
DRAWING	Power and Water: W1-2-18
DESIGN	Stainless steel disc with a central hole for a nail or peg to secure the disc to the kerb. Face of disc stamped or engraved with letters or graphics to identify adjacent service.
MATERIALS	Disc: Stainless steel to ASTM A276 grade 316 or grade 304 or equivalent Nail: Stainless steel to ASTM A276 grade 316 or grade 304 or equivalent
DIMENSIONS	Disc Diameter: 38 mm minimum Nail Diameter: 5 mm minimum Nail Length: 50 mm minimum
USE LIMITS	Use kerb markers on face of kerb Locate kerb markers directly above water services or water mains at road crossings on each side of road and also on median strip kerbs

SURFACE BOXES FOR STOP VALVES

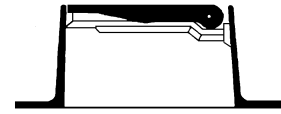
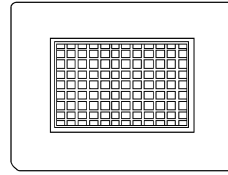

Model	Galvin	Durham
Standard	I	✓
Road pavement		✓

NOTES I = Interim Approval

SURFACE BOXES FOR HYDRANTS

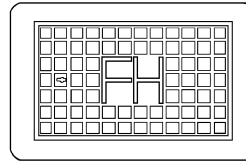

Material	Galvin	Durham
Grey cast iron	I	
Ductile cast iron		✓

I = Interim Approval

Notes: Not for use in roadways

PITS FOR HYDRANTS

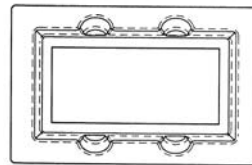

Material	Fylost
Polyethylene	I
GRP	

I = Interim Approval

STANDPIPES FOR HYDRANTS



Shaft material	Mathews
Gal. Steel/copper alloy	
Copper/copper alloy	I
Aluminium alloy	

I = Interim approval

KEY FOR HYDRANT/STOP VALVE

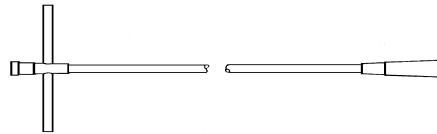

Material	NIBF
Steel	✓
Stainless steel	
Aluminium alloy	

MARKER POSTS FOR UNDERGROUND MAINS AND STOP VALVES



Post



Post marker plates

Use	Crevet
Stop valve	✓
Water retic main	✓
Water rising main	✓

MARKER POSTS FOR HYDRANTS



Post Length (mm)	Crevet
800	I
1800	I

I = Interim approval

MARKING PAINT FOR KERB MARKINGS AND SURFACE BOX TOPS

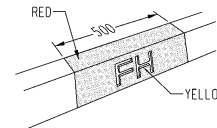

Kerb

Use	IPC (Sunproof acrylic gloss M307)	Wattyl (Killrust epoxy enamel)
Background (red code R13)	✓	I
Letters (yellow code Y14)	✓	

I = Interim approval

PAVEMENT MARKERS FOR HYDRANTS

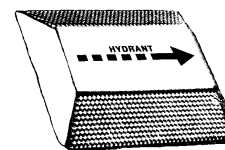

Colour	Stimsonite (911AB)	Avery Dennison (C80)
Blue	✓	I

I = Interim approval

MARKING TAPE FOR UNDERGROUND MAINS



Tape	Boddingtons
Detectable	✓ 1
Non-detectable	I 2

I = Interim approval

NOTES: 1. Wavelay
2. Printguard

KERB MARKER DISCS

	HI-TECH Horizontal Drilling
Kerb Markers	I

I = Interim approval