

8. XLPE - REMOVE SEMI-CON LAYER TO DIMENSION 'S' AS SHOWN. CLEAN AND DEGREASE THE XLPE INSULATION WITH AN APPROVED SOLVENT - CAREFULLY MARK THE REFERENCE LINE ON EACH CORE - THEN DON'T TOUCH IT! REMOVE THE RELEASE PAPER FROM THE RED SEALANT MASTIC STRIP. WRAP ON ONE LAYER STARTING 70mm ON THE SEMI-CON, CONTINUING 100mm ONTO THE INNER SHEATH/SCREEN WIRES. APPLY MASTIC WITH SLIGHT TENSION AND A SMALL OVERLAP.

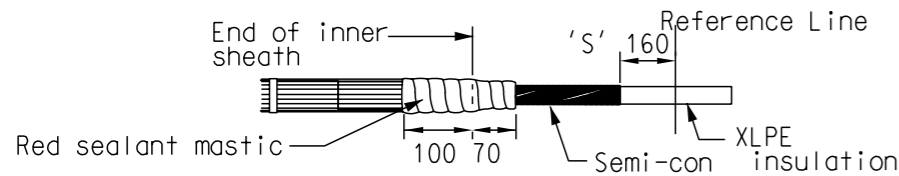

9. XLPE - SLIDE ONE LENGTH OF THE BLACK RE-JACKETING SLEEVE OVER EACH SINGLE CORE CABLE. POSITION INNER END 20mm FROM THE END OF THE SEMI-CON. SHRINK DOWN STARTING AT THE SEMI-CON END CONTINUING ONTO THE SHEATH/SCREEN WIRES.

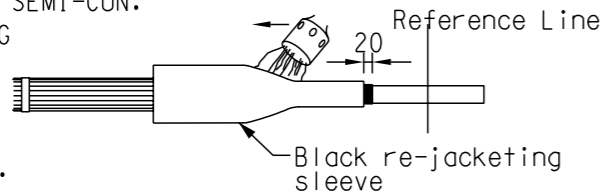

10. XLPE - CLEAN AND DEGREASE THE CABLE SHEATHS. SLIDE THE TERMIMESH TUBE OVER THE SINGLE CORE CABLES. NOTE: IF THE XLPE CABLES ARE SHORT AND THE ENDS ACCESSIBLE THE TERMIMESH MAY BE SLID OVER AFTER JOINT IS COMPLETE. SLIDE THE CABLE BREAKOUT OVER THE SINGLE CORE CABLES WITH THE BREAKOUT FINGERS AWAY FROM THE JOINT.

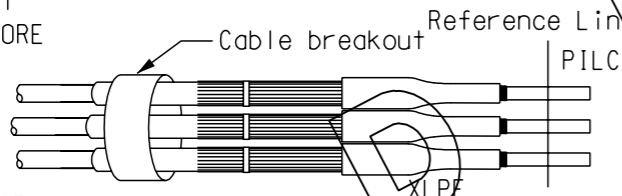

11. PILC - SLIDE ONE OF THE JOINT SEALING SLEEVES OVER THE ALREADY PROTECTED 3 CORE CABLE. FOLD AROUND CABLE AND TAPE IN POSITION. SLIDE THE SECOND JOINT SEALING SLEEVE OVER THE FIRST AND THEN THE BLACK/BROWN JOINT SLEEVE OVER THE OTHERS.

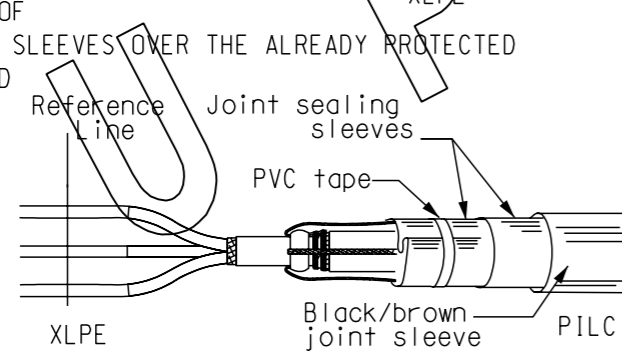

12. POSITION THE CORES AND CUT THEM TO BUTT AT THE REFERENCE LINE (REFER STEP 1 FOR DIMENSIONS). XLPE - COVER THE SCREEN WIRES WITH PLASTIC WRAP AND SLIDE ONE RED INSULATING TUBE OVER EACH SINGLE CORE CABLE. REMOVE INSULATION FROM CONDUCTORS FOR A DISTANCE 'X' EQUAL TO HALF THE CONNECTOR LENGTH + 5mm. CUT A 3mm MAX BEVEL ON THE INSULATION ENDS.

NOTE:- MAX CONNECTOR LENGTH 150MM MAX DIA 35mm  
 - CONNECTORS MUST BE 'BARRIER' TYPES TO BLOCK OIL IN PAPER INSULATION.  
 - CONNECTORS MUST BE 'BARRIER' TYPES TO BLOCK OIL IN PAPER WET WIRE BRUSH (ie UNDER A LIGHT FILM OF JOINTING COMPOUND) THE CONDUCTORS. CRIMP THE CONNECTORS WITH THE APPROPRIATE DIE, REMOVE BURRS AND THOROUGHLY CLEAN OFF EXCESS GREASE FROM CONNECTOR AND CABLE INSULATION. THOROUGHLY CLEAN THE CABLE INSULATION - XLPE AND PILC (REFER INSTRUCTION ON DWG S02-02-02-20). DON'T HANDLE THE INSULATION FROM NOW ON!

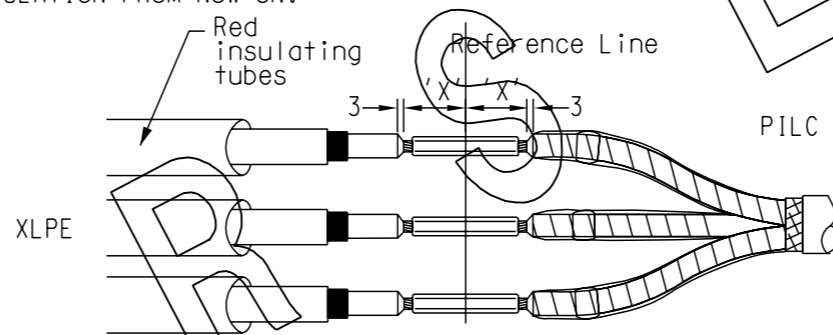

13. REMOVE THE RELEASE PAPER FROM ONE SIDE OF THE YELLOW STRESS CONTROL MASTIC AND ROLL IT UP. WRAP IT AROUND THE CONNECTOR WITH A 50% OVERLAP STRETCHING TO ABOUT HALF ITS WIDTH. FILL THE ENDS OF THE CONNECTOR ENDING 5mm ON TO THE CABLE INSULATION.

NOTE: THE FINAL DIAMETER SHOULD BE ONLY SLIGHTLY GREATER THAN THE CORE INSULATION OR THE CONNECTOR (WHICHEVER IS LARGER). IF THE CONNECTOR DIAMETER IS LARGER THAN THE INSULATION DIAMETER THEN ONLY ONE HALF LAPPED LAYER OF MASTIC IS REQUIRED - ADDITIONAL MASTIC MAY BE REQUIRED IN THE CRIMPED AREAS TO GIVE A SMOOTH PROFILE. REMOVE THE RELEASE PAPERS FROM THE SHORT YELLOW VOID FILLING STRIP. WRAP THE VOID FILLER AROUND THE CORE SEMI-CON SCREEN STARTING 10mm ON THE SCREEN & CONTINUE ONTO THE INSULATION FOR 10mm. STRETCH THE STRIP TO HALF ITS ORIGINAL WIDTH TO ACHIEVE A THIN EDGE.

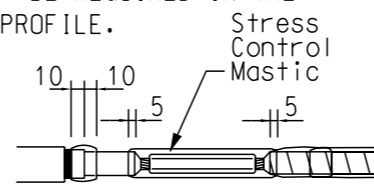

13. ...Cont  
 POSITION THE RED INSULATION TUBE CENTRALLY OVER THE COMPLETED CONNECTOR AREA BEFORE PROCEEDING TO REMAINING CORES. SHRINK DOWN THE 3 RED TUBINGS TOGETHER, STARTING AT THE CENTRE AND WORKING TOWARDS ONE END, THEN THE OTHER. ENSURE THAT THEY ARE FULLY SHRUNK AND FREE FROM WRINKLES.

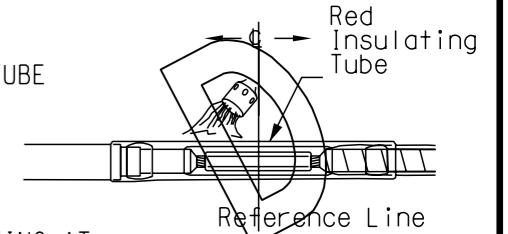

14. PILC - REMOVE COTTON TAPE FROM CRUTCH. INSERT THE YELLOW CRUTCH FILLER WEDGE AS SHOWN ON DRAWING. PUSH WEDGE CAREFULLY INTO THE CRUTCH UNTIL THE TIP IS JUST BELOW THE CWF TAPE. THE WEDGE WILL DEFORM AND PARTLY EXUDE BETWEEN THE CORES. REMOVE THE RELEASE PAPER FROM THE CORE SEPARATOR PROFILE. INSERT AND CENTRE THE PROFILE BETWEEN THE RED TUBINGS. SQUEEZE THE CORES TOGETHER UNTIL THE RED TUBES REST AGAINST THE CORE SEPARATOR.

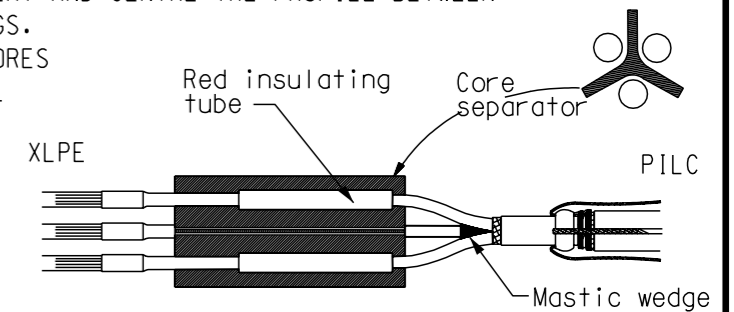

15. REMOVE THE RELEASE PAPER FROM THE BLACK FILLER PROFILES. APPLY 3 PROFILES AT THE SPACES BETWEEN THE CORES - POSITION THE PROFILES 45mm FROM THE LEAD SHEATH, LAYING THEM ALONG THE JOINT AND PUSHING THEM DOWN INTO THE SPACES.

CUT THE 4th PROFILE INTO EQUAL LENGTHS AND LAY THE SHORT PROFILES BETWEEN THE SINGLE CORE CABLES BUTTING THEM TO THE PREVIOUSLY APPLIED PROFILES. THE MASTIC SHOULD END LEVEL WITH THE END OF THE REJACKETING SLEEVES (TRIM IF NECESSARY).

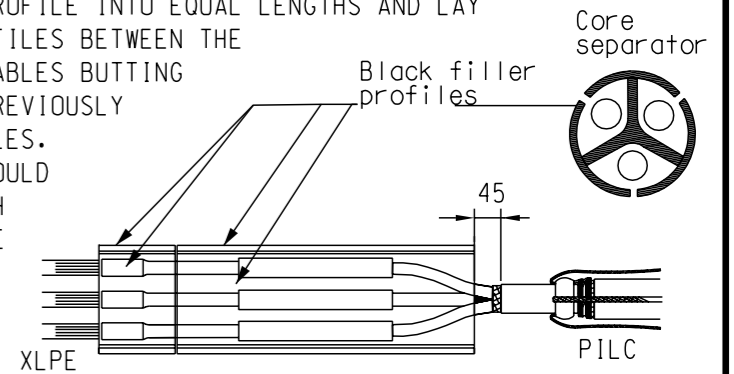

NO	DESCRIPTION	DRN	DATE	CKD	APPD
1	SUPERSEDED	A.T.	DEC'12	B.C.	B.C.
AMENDMENTS					



DES	JEH/ICV 10/96	POWER STANDARD DRAWING	
DRN	R. INNES	<b>CABLE JOINTING &amp; TERMINATIONS</b>	
CKD	-	<b>RAYCHEM JOINTING INSTRUCTIONS</b>	
APPD	F. ROBSON	<b>11kV 3C 400sq.mm SCREENED PILC</b>	
SCALE	NO SCALE	<b>TO 11kV 3x1C 400sq.mm XLPE</b>	
ISSUED	MAY'98	A3	DRAWING NUMBER S02-02-02-31 SHEET 2 of 3
ALL DIM.	IN mm		
DRAFTING STANDARD TO A.S.1100		CAD PRODUCT - DO NOT AMEND MANUALLY	

