

PLAN VIEW
SCALE 1:25

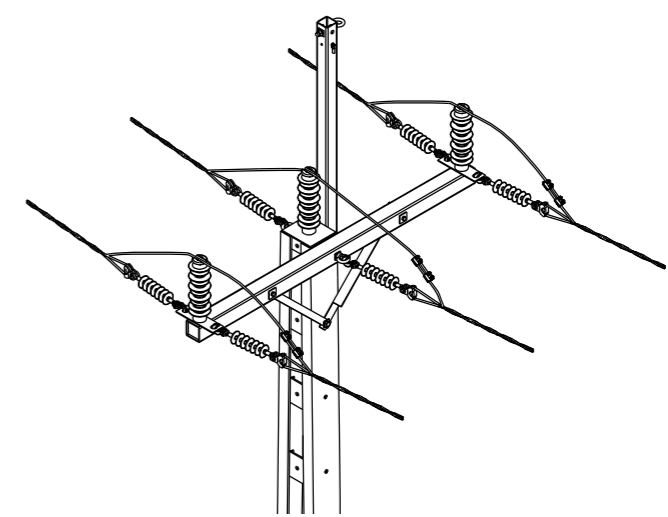

ISOMETRIC VIEW
SCALE N.T.S.

AERIAL RISER TO POLE 2 OFF CONNECTIONS, USE M24 BOLT 180 LONG, 2 X LARGE FLAT WASHERS, SPRING WASHER AND M24 NUT. ALLOW EXTRA THREE WASHERS BETWEEN POLE BRACE AND RISER AT BOTH CONNECTIONS

FOR CENTRE PHASE TERMINATION, USE M24 BOLT 50 LONG, 4 X LARGE FLAT WASHERS, SPRING WASHER AND M24 EYE NUT (18kN)

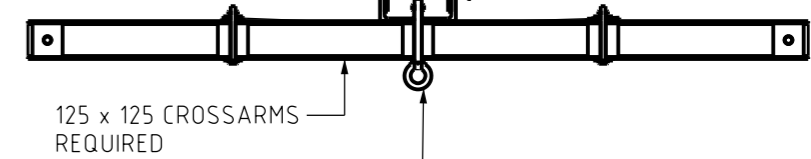

125 x 125 CROSSARMS REQUIRED

FOR CENTRE PHASE TERMINATION AND CROSSARM TO POLE CONNECTION, USE M24 GALVANISED THREADED ROD, 2 X LARGE FLAT WASHERS, SPRING WASHER AND M24 EYE NUT (18kN)

SECTION VIEW
SCALE 1:25

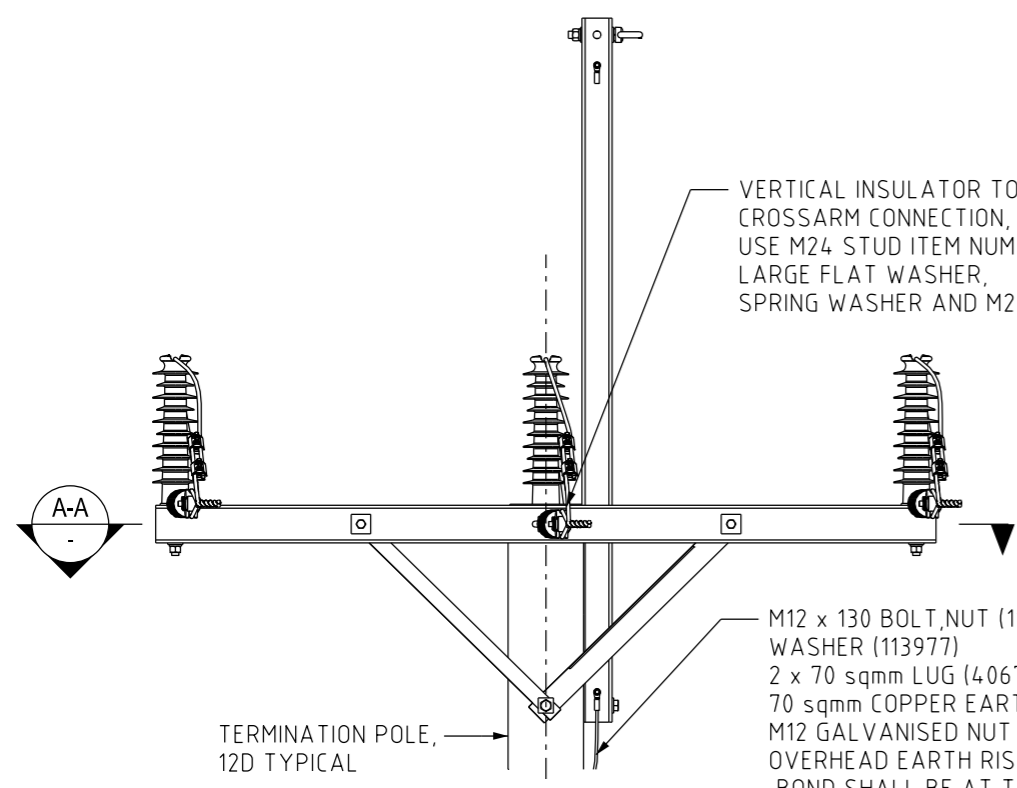

FRONT VIEW
SCALE 1:25

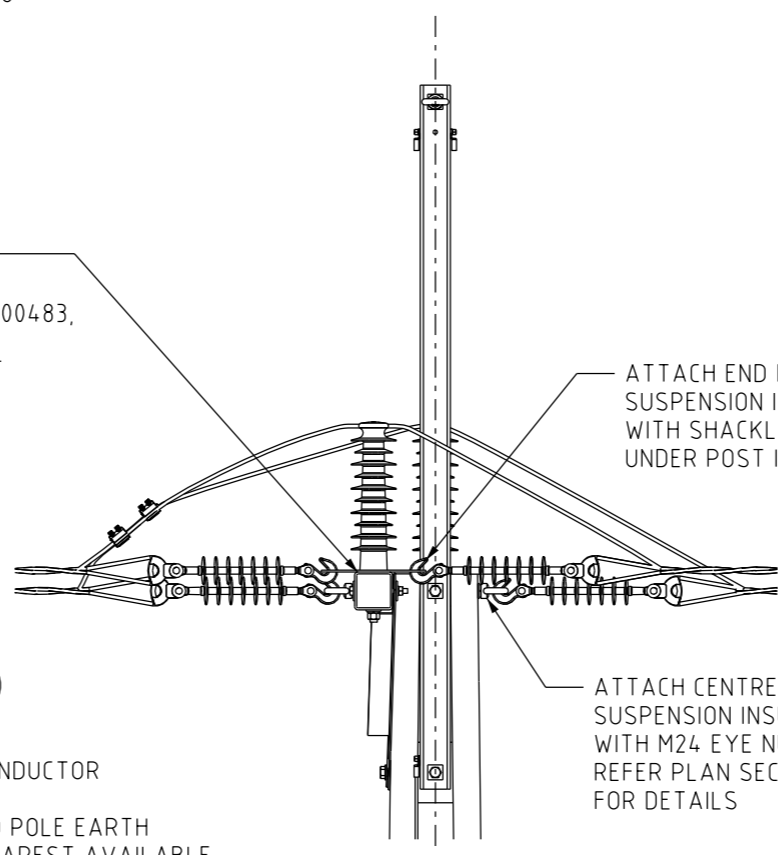

FRONT SIDE
SCALE 1:25

NO	DESCRIPTION	DRN	DATE	CKD	APPD
6	CROSSARM AMENDED	C.C.	JUN'21	B.C.	B.V.
5	TITLEBLOCK & DRAWING NUMBERS FORMATTED	P.H.	APR'18	I.B.	B.C.
4	ITEM NUMBER AMENDED	P.H.	APR'18	I.B.	B.C.
3	AMENDED LABELS	C.M.	JAN'10	A.T.	S.C.
2	RENAMED AND UPDATED CROSSARM CONSTRUCTION	C.M.	JAN'10	A.T.	S.C.
1	ADD EARTH BOND	C.M.	JAN'10	A.T.	S.C.
0	ISSUED FOR CONSTRUCTION	A.S.	7.3.01	M.B.	F.R.R.



DES	M. BOCK	POWER STANDARD DRAWING	
DRN	R. INNES	ASSEMBLIES, O/H EARTH WIRE ON HV C TOP CONSTRUCTION FOR UNIVERSAL POLE CONSTRUCTION	
CKD	M. BOCK		
APPD	F. ROBSON	A3	DRAWING NUMBER S01-02-01-23
SCALE	AS SHOWN		
ISSUED	JULY'00	DRAFTING STANDARD TO A.S.1100	
ALL DIM. IN	mm		
CAD PRODUCT - DO NOT AMEND MANUALLY		AMDT	