

**PRE-ARCING CURRENTS FOR EXPULSION FUSE LINKS CLASS 'K' (SPARKLESS)**

ITEM	ITEM NUMBER	CURRENT RATING (A)	PRE-ARCING CURRENT RATINGS (A)						NOMINAL BUTTON HEAD DIAMETER 'D' (mm)	19 mm BUTTON HEAD WASHER
			300 or 600 s (SEE NOTE 4)		10 s		0.1 s			
			MIN.	MAX.	MIN.	MAX.	MIN.	MAX.		
1	187765	5	10	12	11	17	58	70	12.7	YES
2	187773	8	15	18	18	27	97	116	12.7	YES
3	187781	10	19	24	22	34	128	154	12.7	YES
4	255810	16	32	39	37	58	225	270	12.7	YES
5	255828	20	39	47	48	71	273	328	12.7	YES
6	255836	25	50	60	60	90	350	420	12.7	YES
7	255844	31.5	65	79	79	118	450	570	12.7	YES
8	255851	40	80	96	98	146	565	680	12.7	YES
9	255869	50	101	121	126	188	719	862	12.7	YES
10	255877	63	125	150	155	230	880	1050	19	NO
11	255885	80	160	192	205	307	1180	1420	19	NO
12	283226	100	200	240	258	388	1520	1820	19	NO
13	407373	200	480	576	760	1150	3880	4650	25	NO

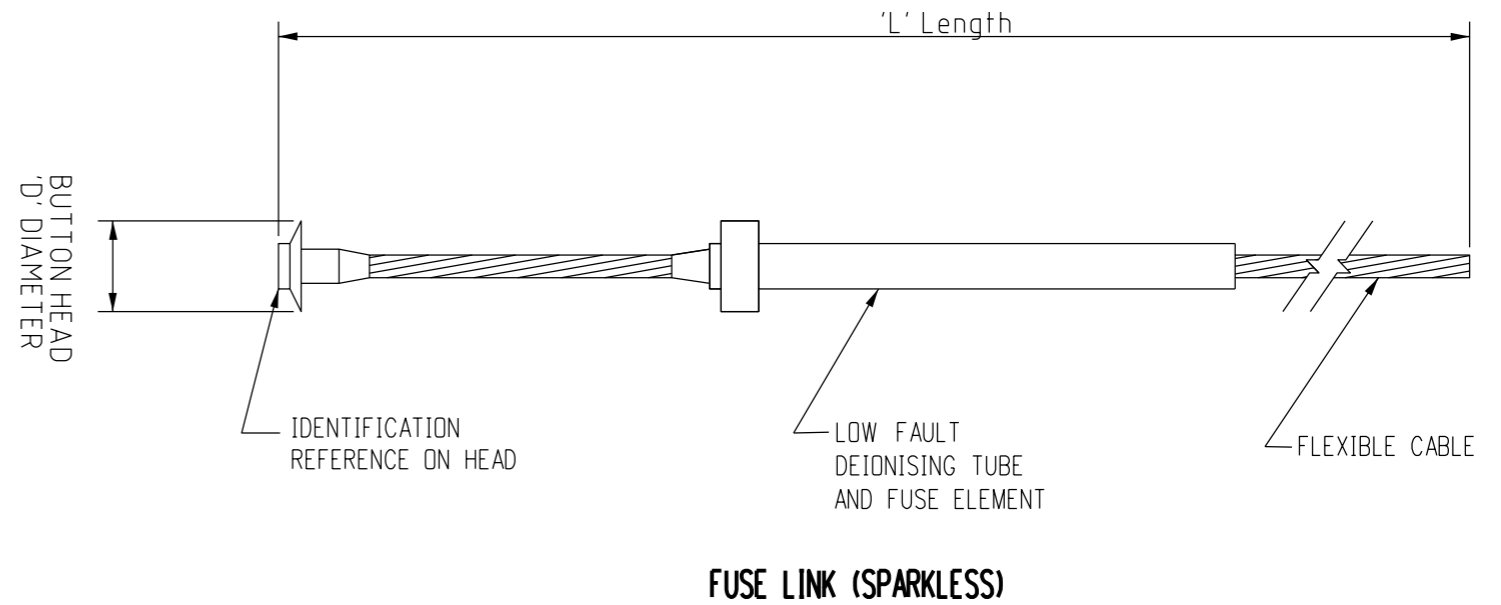

**NOTES**

- REFER TO S01-04-02-01 & S01-04-02-02 FOR FUSE LINK SIZE APPLICATIONS
- FUSE CHARACTERISTICS IN ACCORDANCE WITH AS 1033.1 TABLE A1.
- 300s - FOR FUSE-LINKS RATED UP TO AND INCLUDING 100A.  
600s - FOR FUSE LINKS ABOVE 100A.
- ITEM 13 FOR USE ONLY WITH 200A EDO BARREL (ITEM NUMBER 407372). 200A BARREL AND FUSE CAN BE FITTED TO STANDARD 22kV EDO ASSEMBLY (ITEM NUMBER 3863). ITEM 13 ONLY FOR USE IN VOLTAGE REGULATOR INSTALLATIONS.
- NOMINAL OVERALL LENGTH 'L' EITHER 584mm (PREFERRED) OR 660mm.
- FUSE LINKS TO SUIT BOTH 11 & 22 kV APPLICATIONS.

NO	DESCRIPTION	DRN	DATE	CKD	APPD
9	UPDATED PRE-ARCING TABLE TO AS1033.1 A1. ADDED NOTES 6 & 7. CLARIFIED DIMENSIONS OF FUSE LINKS. CHANGED TITLE. AMENDED NOTE 1 TO DRAWING REFERENCE. REMOVED NOTE 2.	A.N.	JAN'21	C.C.C.	B.C.
8	TITLEBLOCK & DRAWING NUMBER FORMATTED	K.T.	DEC'18	C.C.	C.C.
7	ITEM 1 DETAILS AMENDED	C.C.	AUG'17	I.B.	B.C.
6	DRAWING FRAME UPDATED, NOTE 5 ADDED	C.C.	FEB'13	A.T.	B.C.
5	ITEM 13 ADDED, NOTE 3 CHANGED, NOTE 4 ADDED	C.W.M.	AUG'08	A.G.	B.C.
4	ITEMS 1-10 & 14 REMOVED, FUSE LINK DETAIL REMOVED, NOTES 3 & 4 REMOVED.	R.G.I.	NOV'99	F.R.R.	G.H.
3	REPLACEMENT STOCK CODES ADDED, 100A FUSE LINK ADDED, NOTE 4 ADDED.	J.A.L.	FEB'97	F.R.R.	A.G.B.



DES	G.SCHUBERT	POWER STANDARD DRAWING		
DRN	W.TAYLOR	<b>SWITCHGEAR</b> <b>M.V.</b> <b>FUSE LINKS EXPULSION (SPARKLESS)</b>		
CKD	G.MCKINNON			
APPD	B.T.KENT			
SCALE	N.T.S.			
ISSUED	15/09/87	A3	DRAWING NUMBER	S01-01-06-05
ALL DIM.	IN mm			
DRAFTING STANDARD TO A.S.1100		CAD PRODUCT - DO NOT AMEND MANUALLY		

