

NOTES:

1. JUNCTION BOX TO BE POWER FIXED TO POLE AT POSITION SHOWN.
2. 35 sq.mm ACTIVE TAILS TO BE PHASE COLOURED WITH HEATSHRINK TUBING BEFORE CONNECTION TO JUNCTION BOX.
3. FOR DETAILS OF FUSE HOLDER AND COMPONENTS REFER TO DRAWING No. S01-01-04-49
4. SERVICES TO BE CONNECTED TO FUSE HOLDER DIRECTLY OPPOSITE SERVICE HOOK.

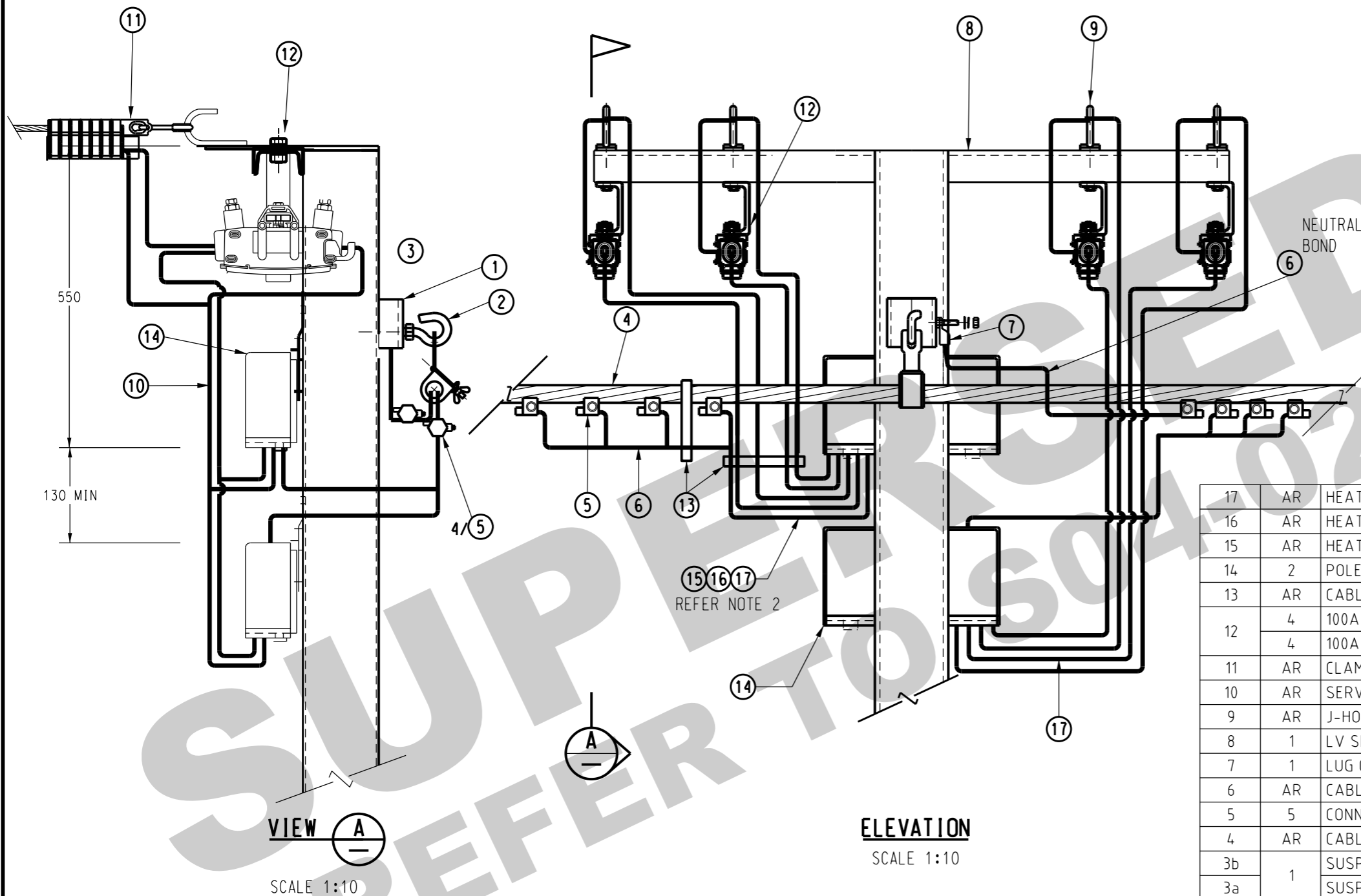

17	AR	HEATSHRINK TUBING 19.1 - 9.5mm RED	4093	S02-01-02-15
16	AR	HEATSHRINK TUBING 19.1 - 9.5mm WHITE	4101	S02-01-02-15
15	AR	HEATSHRINK TUBING 19.1 - 9.5mm BLUE	4127	S02-01-02-15
14	2	POLE TOP LV-ABC JUNCTION BOX	206169	S04-01-03-04
13	AR	CABLE TIE 8mm BLACK UV RESISTANT	208017	-
12	4	100A SERVICE FUSE ASSEMBLY	241109	S01-01-04-49
	4	100A SERVICE FUSE ASSEMBLY MOUNTING BRACKET	406802	S01-01-04-49
11	AR	CLAMP STRAIN SERVICE 2x16 SQ.MM	251660	S01-01-04-28
10	AR	SERVICE CONDUCTOR 2 CORE 16 SQ.MM	286088	S01-01-07-03
9	AR	J-HOOK WITH STRAP	9324	S01-01-04-07
8	1	LV SERVICE CROSSARM 100x50x4 DURAGAL CC	298554	S01-01-02-11
7	1	LUG COMPRESSION Cu 35 SQ.MM M12	156240	S02-01-02-11
6	AR	CABLE 35 SQ.MM Cu	407083	S02-01-01-35
5	5	CONNECTOR, PIERCING 150-50/35-6 SQ.MM	415586	S04-01-02-15
4	AR	CABLE LV-ABC AI 4x95 SQ.MM	197665	S04-01-01-01
3b		SUSPENSION CLAMP 4x95 SQ.MM	197681	S04-01-02-10
3a	1	SUSPENSION CLAMP 4x95 SQ.MM ROLLER COMBO.	198408	S04-01-02-10
2	1	HOOK BOLT M16 NON-BREAKAWAY ASSEMBLY	3160	S04-01-02-07
			197731	
1	1	BRACKET HOOK MOUNTING	213879	S04-01-02-02
			203679	
ITEM	QTY	DESCRIPTION	ITEM NUMBER	DRG. REF.

ELEVATION
SCALE 1:10

VIEW A
SCALE 1:10

MATERIAL SCHEDULE

NO	DESCRIPTION	DRN	DATE	CKD	APPD
6	SUPERSEDED TO S04-02-01-26	A.N.	SEP'21	A.N.	B.V.
5	REFORMATTED TABLE AND NOTES. UPDATED ITEMS 3, 5, 6 7, 8, 10, 11, 12 & 13. UPDATED TERMINATION IMAGERY	A.N.	JUL'21	A.N.	B.C.
4	TITLEBLOCK & DRAWING NUMBER FORMATTED	K.T.	DEC'19	C.C.	C.C.
3	CURRENT BREAKER REPLACED WITH FUSE HOLDER	J.C.	FEB'08	B.C.	S.C.
2	2nd JUNCTION BOX (ITEM 14) ADDED	A.S.	JUN'07	B.C.	S.C.
1	REDRAWN ON CAD	A.D.	MAY'98	R.I.	F.R.

PowerWater
NORTHERN TERRITORY

DES	B.T. KENT	POWER STANDARD DRAWING	
DRN	A. DAVIES	ASSEMBLIES	
CKD	R. INNES	LV - ABC	
APPD	F. ROBSON	3-4 SERVICES	
SCALE	AS SHOWN	INTERMEDIATE SUSPENSION	
ISSUED	MAY '98	A3	DRAWING NUMBER S04-02-01-15
ALL DIM. IN mm			
DRAFTING STANDARD TO A.S.1100		CAD PRODUCT - DO NOT AMEND MANUALLY	