

ITEM 1: INSULATOR STUD

ITEM NUMBER: 502248
SCALE 1:1

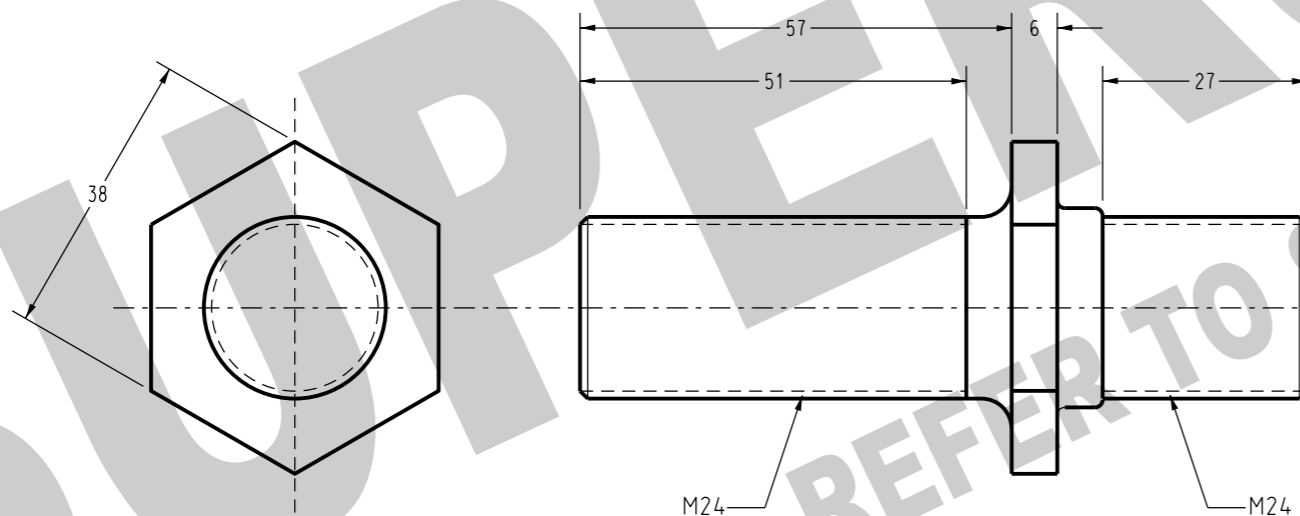

ITEM 2: INSULATOR STUD

ITEM NUMBER: 12088
SCALE 1:1

NOTES:

- MATERIAL - FORGED STEEL, NORMALISED AFTER FORGING, FAILING LOAD 13kN.

NO	DESCRIPTION	DRN	DATE	CKD	APPD
2	CHANGED 'STOCK CODE' TO 'ITEM NUMBER'. ADDED ITEM 2 ITEM NUMBER. SUPERSEDED TO S01-01-04-44	A.N.	JUL'21	C.C.C.	B.V.
1	TITLEBLOCK & DRAWING NUMBER FORMATTED	K.T.	DEC'18	C.C.	C.C.
AMENDMENTS					



DES	-	POWER STANDARD DRAWING		
DRN	R. INNES	LINE HARDWARE INSULATOR STUD 66KV LINE POST INSULATOR		
CKD	-			
APPD	F. ROBSON			
SCALE	AUG'99			
ISSUED	1:1	A3	DRAWING NUMBER	S01-01-04-34
ALL DIM. IN mm				
DRAFTING STANDARD TO A.S.1100		CAD PRODUCT - DO NOT AMEND MANUALLY		