

**NOTES :**

- UP TO 2 SINGLE PHASE SERVICES CAN BE CONNECTED DIRECT TO ABC. FOR ARRANGEMENTS REQUIRING MORE THAN 5 PIERCING CONNECTORS, USE POLE MOUNTED JUNCTION BOX. REFER TO DRG S04-01-02-15 FOR DETAILS.
- ACTIVE SERVICE TEE-OFF TO BE BALANCED OVER THREE PHASES ON SUBSEQUENT POLES.
- SERVICES TO BE CONNECTED TO FUSE HOLDER DIRECTLY OPPOSITE SERVICE HOOK.
- FOR FUSE HOLDER ASSEMBLY DETAILS REFER TO S01-01-04-49

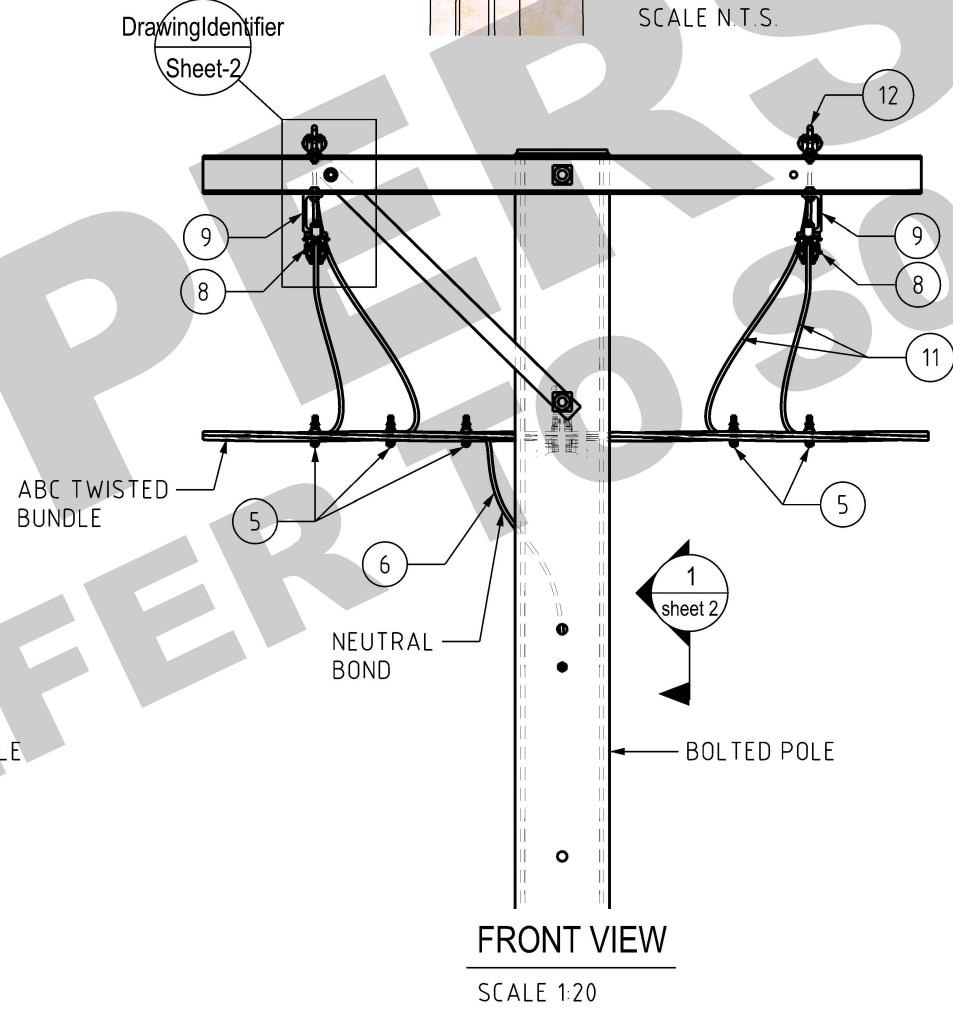
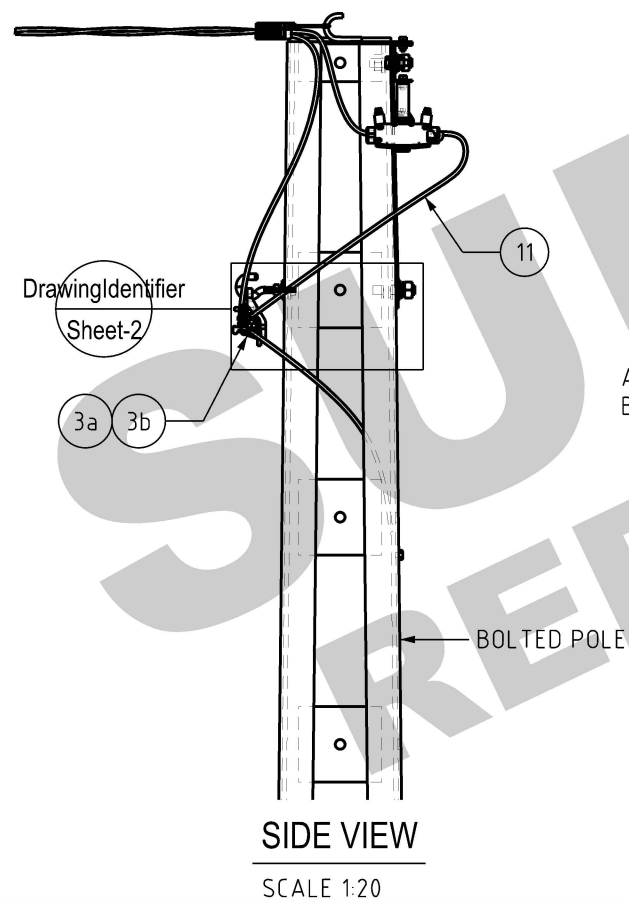

ITEM	QTY	DESCRIPTION	ITEM No.	DRG REF
13	X	BOLT & NUT M16 X 50 ZINC PLATED	114504	S01-02-01-03
12	X	HOOK STRAP	9324	S01-01-04-07
11		CONDUCTOR SERVICE 2 X 7/1.70	9779	-
9	X	ALUMINIUM BRACKET	4106802	S01-01-04-49
8	X	SERVICE FUSE BASE WITH FUSE HOLDER	241109	S01-01-04-49
7	1	LUG COMPRESSION 35sq.mm	156240	S02-01-02-11
6	-	CABLE Cu PVC 35sq.mm BLACK	1586	S01-02-01-31
5	-	CONNECTOR, PIERCING 150-50 / 25-6 SQ.MM	415586	S04-01-02-15
4	-	CABLE LV ABC, 4 X 95sq.mm	197665	S04-01-01-01
3b	1	CLAMP SUSPENSION COMBINATION 4 X 95sq.mm	198408	S04-01-02-10
3a	1	CLAMP SUSPENSION 4 X 95sq.mm	197681	S04-01-02-10
2b	1	HOOK BOLT M16	197731	S04-01-02-07
2a	1	HOOK BOLT M16 NON-BREAKAWAY ASSEMBLY	-	S04-01-02-07
1	1	BRACKET HOOK MOUNTING	203679	S04-01-02-02

MATERIAL SCHEDULE

NO	DESCRIPTION	DRN	DATE	CKD	APPD
5	SUPERSEDED TO S04-02-01-25	A.N.	SEP'21	A.N.	B.V.
4	TITLEBLOCK & DRAWING NUMBER FORMATTED	K.T.	JAN'20	C.C.	C.C.
3	ITEM AND DRAWING NUMBER AMENDED	C.C.	SEP'19	B.V.	B.C.
2	CIRCUIT BREAKERS REPLACED WITH FUSE HOLDERS	J.C.	FEB'08	A.T.	S.C.
1	REDRAWN ON CAD	A.D.	JAN'98	R.I.	F.R.

AMENDMENTS



DES	B.T.KENT	POWER STANDARD DRAWING	
DRN	A.DAVIS	ASSEMBLIES	
CKD	R.INNES	LV - ABC 1 - 2 SERVICES	
APPD	F.ROBSON	INTERMEDIATE SUSPENSION	
SCALE	N.T.S.	(SHEET 1 OF 2)	
ISSUED	MAY 1998	A3	DRAWING NUMBER
ALL DIM. IN mm			S04-02-01-14_1
DRAFTING STANDARD TO A.S.1100		CAD PRODUCT - DO NOT AMEND MANUALLY	



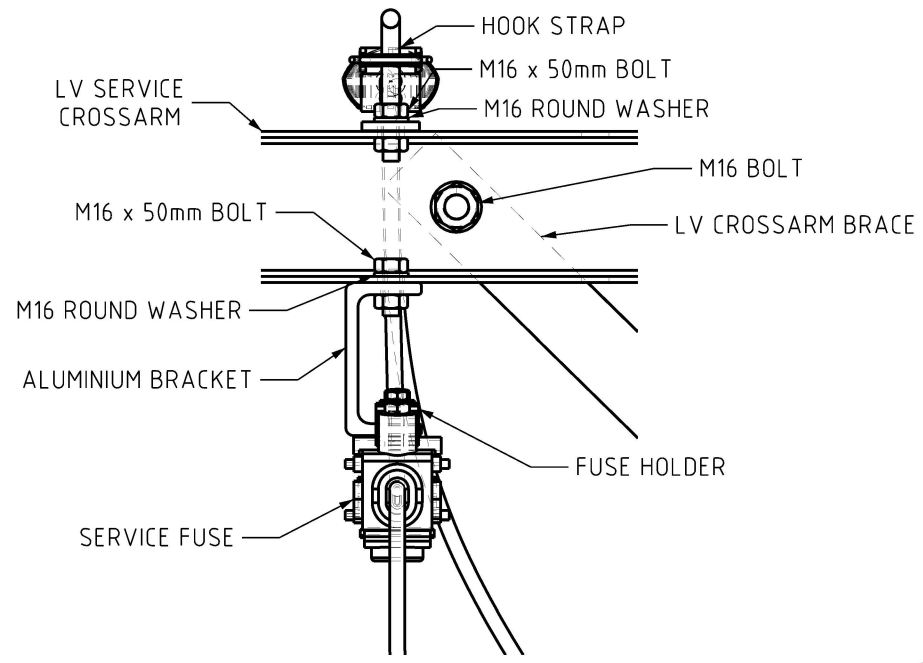

1 DETAIL  
Sheet-2 1:5

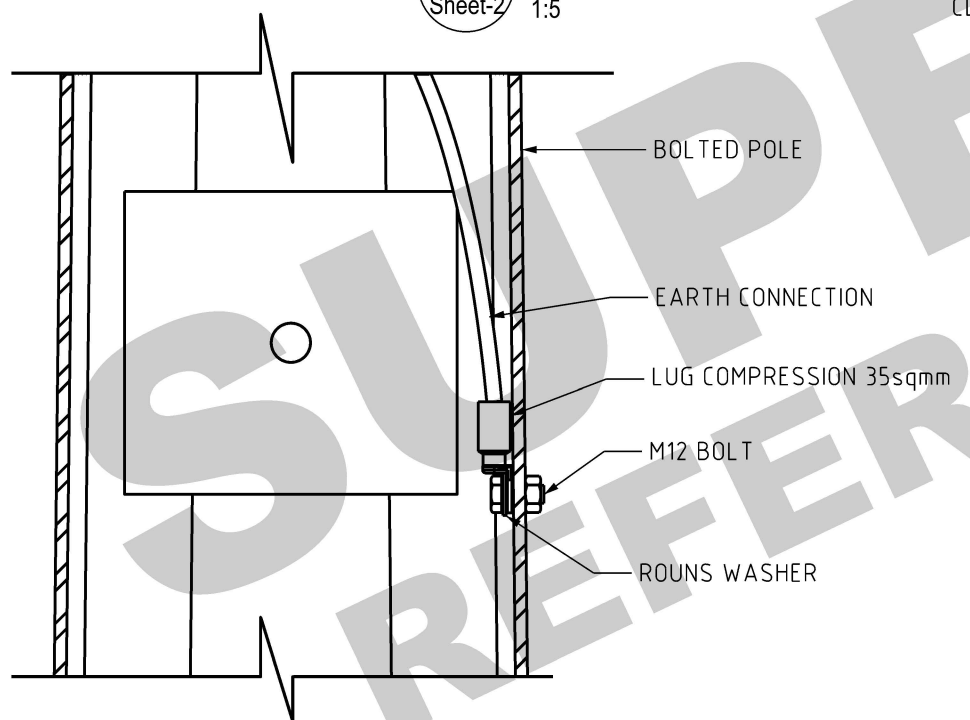

1 SECTION 1  
Sheet-2 1:5

NOTE ABC TWISTED BUNDLE, CABLES & CONNECTOR, PIERCING HAVE BEEN REMOVED FOR CLARITY

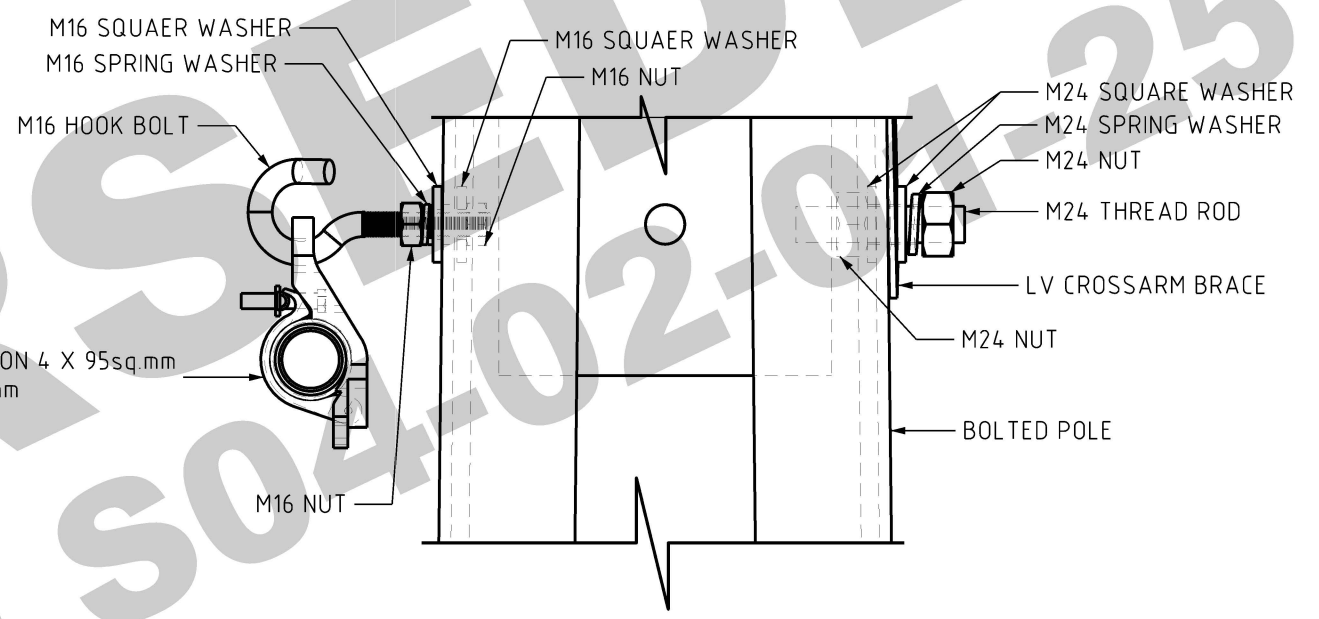

2 DETAIL  
Sheet-2 1:5

CLAMP SUSPENSION COMBINATION 4 X 95sq.mm  
CLAMP SUSPENSION 4 X 95sq.mm

NO	DESCRIPTION	DRN	DATE	CKD	APPD
2	SUPERSEDED TO S04-02-01-25	A.N.	SEP'21	A.N.	B.V.
1	TITLEBLOCK & DRAWING NUMBER FORMATTED	K.T.	DEC'19	C.C.	C.C.
0	ITEM AND DRAWING NUMBER AMENDED	C.C.	SEP'19	B.V.	B.C.
AMENDMENTS					



DES	B.T.KENT
DRN	A.DAVIS
CKD	R.INNES
APPD	F.ROBSON
SCALE	N.T.S.
ISSUED	MAY 1998
ALL DIM. IN mm	
DRAFTING STANDARD TO A.S.1100	

POWER STANDARD DRAWING	
ASSEMBLIES	
LV - ABC 1 - 2 SERVICES	
INTERMEDIATE SUSPENSION	
(SHEET 2 OF 2)	
A3	DRAWING NUMBER S04-02-01-14_2
CAD PRODUCT - DO NOT AMEND MANUALLY	

