

3RD ANGLE -DO NOT SCALE - REPORT ANY ERRORS, OMISSIONS TO DRAFTING OFFICE

BY

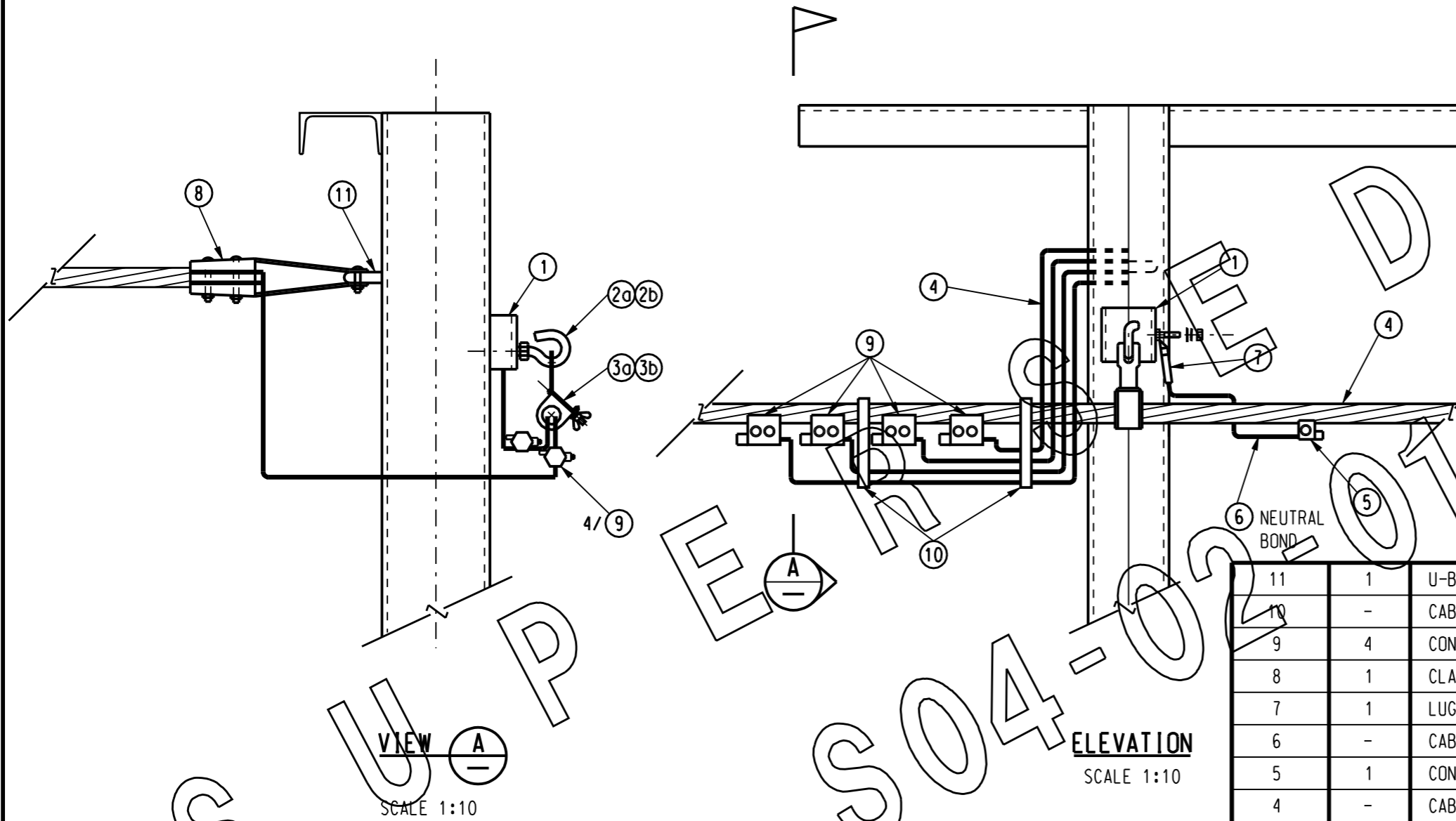

NOTES

1. REFER SERVICING DRAWINGS FOR SERVICE ARRANGEMENTS.
2. CABLE TIES TO BE USED AS REQUIRED.

VIEW A
SCALE 1:10

ELEVATION
SCALE 1:10

ITEM	QTY	DESCRIPTION	ITEM No	DRG REF
11	1	U-BEND	9159	
10	-	CABLE TIE BLACK 8mm		
9	4	CONNECTOR PIERCING 95/95	197715	
8	1	CLAMP STRAIN 4x95mm	197707	
7	1	LUG COMPRESSION 35sq.mm	156240	
6	-	CABLE Cu PVC 35sq.mm	1586	-
5	1	CONNECTOR, PIERCING 95/35	197723	S04-01-02-15
4	-	CABLE LV ABC, 4x95sq.mm	197665	S04-01-01-01
3b	1	CLAMP SUSPENSION COMBINATION 4x95sq.mm	198408	S04-01-02-10
3a	1	CLAMP SUSPENSION 4x95sq.mm	197681	S04-01-02-10
2b	1	HOOK BOLT M16	197731	S04-01-02-07
2a	1	HOOK BOLT M16 NON-BREAKAWAY ASSEMBLY	-	S04-01-02-07
1	1	BRACKET HOOK MOUNTING	203679	S04-01-02-02

MATERIAL SCHEDULE

NO	DESCRIPTION	DRN	DATE	CKD	APPD
2	TITLEBLOCK & DRAWING NUMBER FORMATTED	K.T.	JAN'20	C.C.	C.C.
1	REDRAWN ON CAD	A.D.	MAY'98	R.I.	F.R.
AMENDMENTS					



DES	B.T.KENT	POWER STANDARD DRAWING		
DRN	A.DAVIS	POLE TOP UNITS		
CKD	R.INNES	LV-ABC		
APPD	F.ROBSON	SUSPENSION ANGLE TEE-OFF		
SCALE	N.T.S.	PROPERTY SIDE		
ISSUED	MAY'98	A3	DRAWING NUMBER	S04-02-01-12
ALL DIM. IN mm				
DRAFTING STANDARD TO A.S.1100		CAD PRODUCT - DO NOT AMEND MANUALLY		AMDT