

TEE JUNCTION - TYPE 1

TEE JUNCTION - TYPE 2

TEE JUNCTION SCHEDULE

DN1	DN2	L1	L2	T1	W1	T2	DB	DW	DT
1350	750						270	270	
1050	750						270	270	
750	600								
750	150	1000	800	4.5	63				
750	150	1000	800	4.5	63				
750	750	1500	750			25	440	440	210
600	300	1500	600	4.5	112				
600	600	1500	600			25	290	290	160
600	450	1500	600	4.5	254				
600	450	1500	600	4.5	254				

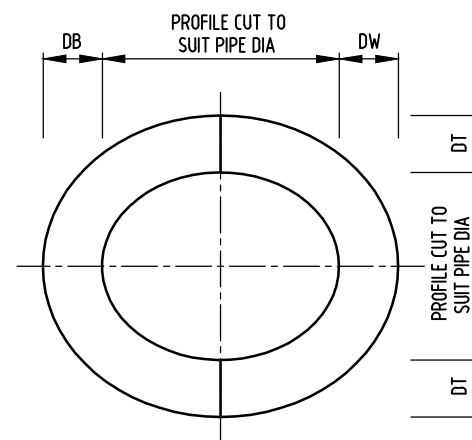
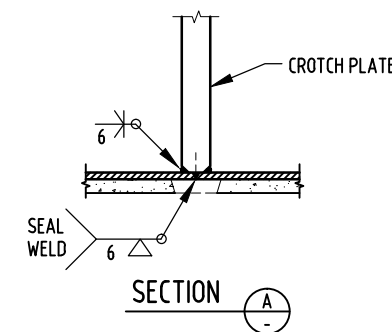
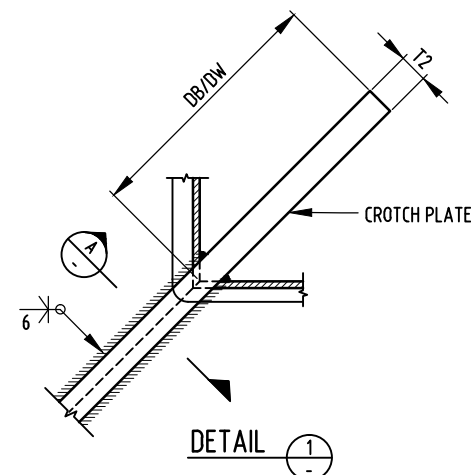

TEE JUNCTION
CROTCH PLATE/ WRAPPER REINFORCEMENT

CROTCH PLATE/ WRAPPER REINFORCEMENT SCHEDULE

JUNCTION TYPE	ANGLE	T1	W1	T2	DB	DW	DT
DN750 x DN750 TEE	90°			25	440	440	210
DN750 x DN600 TEE	90°			25	240	240	180
DN600 x DN600 TEE	90°			25	290	290	160
DN600 x DN450 WYE	45°			25	185	232	140
DN600 x DN450 TEE	90°	4.5	254				
DN600 x DN300 TEE	90°	4.5	112				

NOTES:

- ALL STEEL USED FOR COLLARS SHALL BE IN ACCORDANCE WITH AS.3678.
- ALL WELDED JOINTS TO BE MECHANICAL WIRE BRUSH CLEANED AND COATED WITH INORGANIC ZINC SULFATE PRIMER (MINIMUM 75 MICRONS).
- ALL WELDS TO BE CONTINUOUS FULL WELD ALL ROUND TO MAIN PIPE AND BRANCH IN ACCORDANCE WITH AS.1554.1 CATEGORY SP UNLESS NOTED OTHERWISE.
- TEST HOLES ARE PROVIDED TO ENABLE GAP UNDER COLLARS TO BE PRESSURISED TO CONFIRM COMPLETE WELDING INTEGRITY, HOLES SHALL BE PLUGGED WITH A SOCKET HEAD PLUG WITH TAPER THREAD UPON COMPLETION.
- FIELD MORTAR CEMENT LINING TO BE REINSTALLED IN ACCORDANCE WITH MANUFACTURER'S SPECIFICATION.
- ALL MAIN FLANGES TO BE RAISED FACE TYPE COMPLYING WITH AS.4087 FIGURE B7.
- ALL FITTINGS TO BE ASSEMBLED IN THE FACTORY AND NOT ON SITE. FBPE COATING TO BE APPLIED AFTER FABRICATION.
- PIPE DIAMETERS & WALL THICKNESS FOR FABRICATED FITTING TO BE AS FOLLOWS: DN150 - 168 OD x 5.0mm, DN300 - 356 OD x 5.0mm, DN450 - 508 OD x 6.0mm, DN600 - 660 OD x 6.0mm, DN750 - 813 OD x 7.0mm.
- ALL MATERIAL AND WORKMANSHIP SHALL BE IN ACCORDANCE WITH THE RELEVANT STANDARDS AUSTRALIAN CODES, EXCEPT WHERE VARIED BY THE PROJECT SPECIFICATION.
- 4 PART PETROLATUM TAPE SYSTEM TO BE SUITABLE FOR BELOW GROUND TROPICAL CLIMATE INSTALLATION: PRIMER, MASTIC FILLER, TAPE & PVC OVER WRAP TAPE.

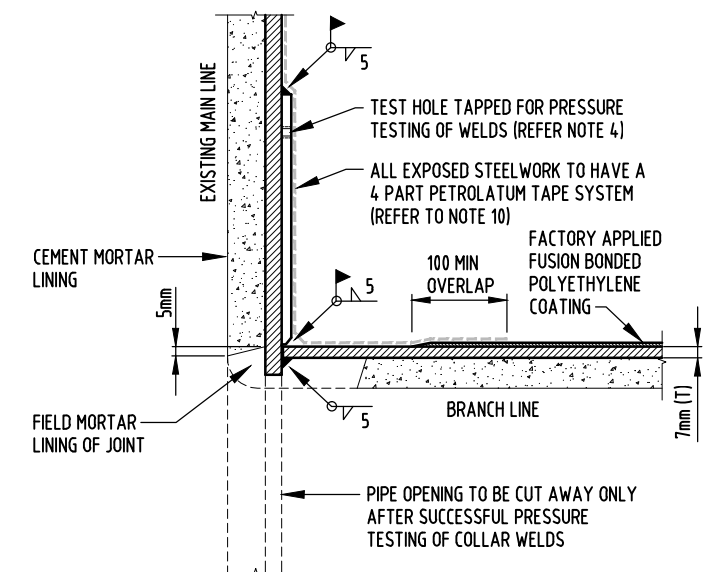

DETAIL 2

1	REDRAWN ON CAD. GENERAL AMENDMENTS 2021.	PW	JUNE'21	IL	DC
NO	DESCRIPTION	DRN	DATE	CKD	APPD
AMENDMENTS					



DES	IL	WATER STANDARD DRAWING	
DRN	PW	MAINLAYING	
CHK	IL	STANDARD WELDED STEEL PIPE	
APPD	DC	REINFORCEMENT	
SCALE	N.T.S.	A3	DRAWING NUMBER W1-2-06B
ISSUED	JUN'21	1	
ALL DIM. IN mm		CAD PRODUCT - DO NOT AMEND MANUALLY	
DRAFTING STANDARD TO A.S.1100		AMDT	