

**ITEM 1**

ITEM 1 - SERVICE CLAMP - STRAIN - 2 X 6sq.mm TO 4 X 35sq.mm.  
(ITEM NUMBER: 251660)  
ONLY FOR USE ON SINGLE PHASE URBAN SERVICES WITH SPANS LESS THAN 30M LONG

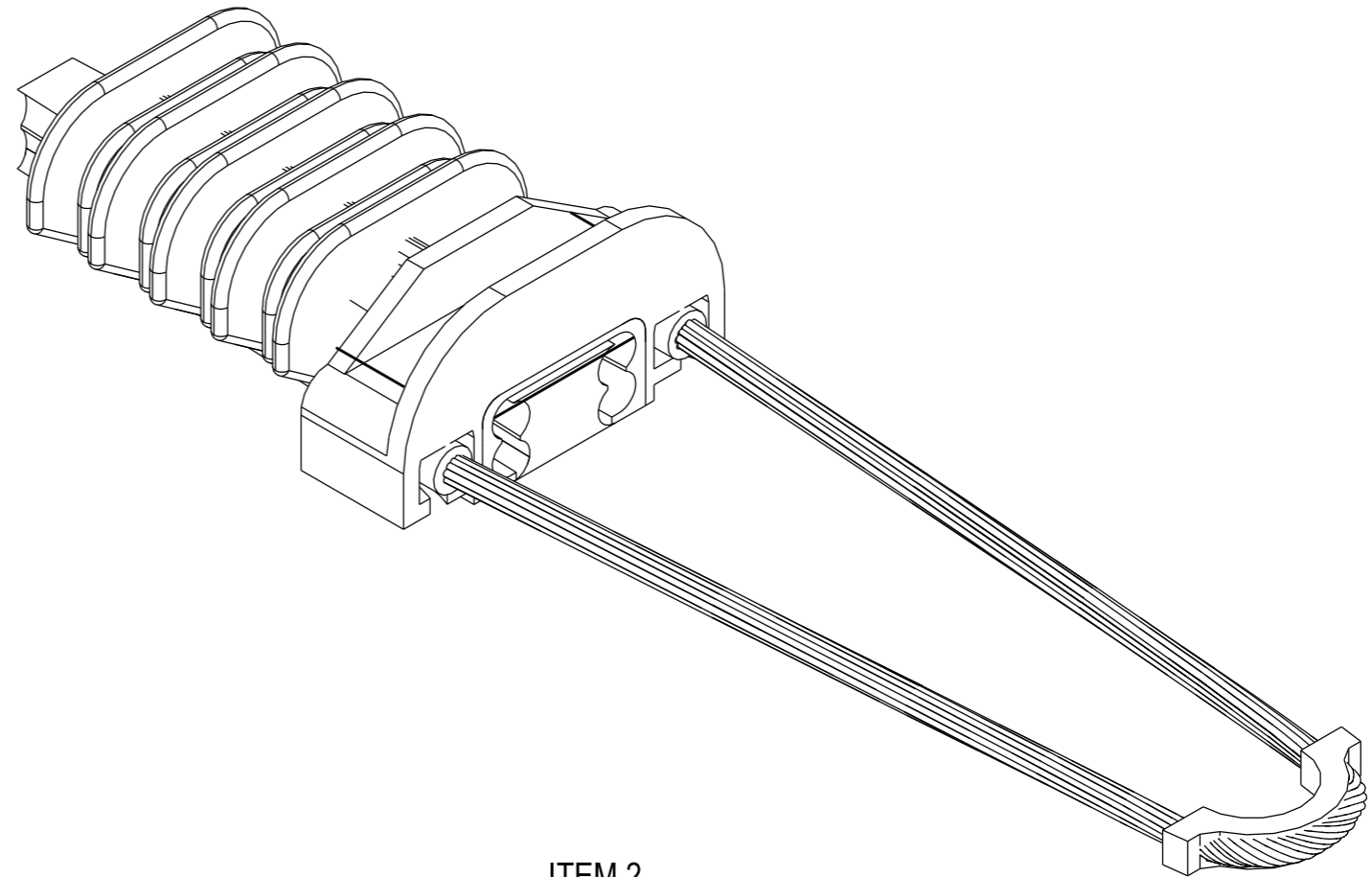

**ITEM 2**

ITEM 2 - SERVICE CLAMP - STRAIN - 2 X 16sq.mm TO 4 X 25sq.mm.  
(ITEM NUMBER: 408998)  
FOR USE ON: - ALL 3 PHASE SERVICES - ALL RURAL SERVICES - SINGLE PHASE URBAN SERVICES WITH CONDUCTOR SPANS GREATER THAN 30M

**NOTES:**

1. BAIL MUST BE MADE OF STAINLESS STEEL AND DETACHABLE TO SUIT CLOSED EYE BRACKET.
2. MATERIAL OF BODY AND WEDGE TO BE OF GLASS REINFORCED, UV RESISTANT POLYMER.
3. CLAMPS ARE SUITABLE FOR USE WITH XLPE SERVICE CONDUCTOR. REFER TO DRG NO S01-01-07-03 FOR DETAILS.
4. CLAMP MUST HAVE ADJUSTABLE WEDGE TO SUIT A RANGE OF CABLE SIZES AS SPECIFIED.
5. CLAMP MUST BE USED IN CONJUNCTION WITH DRG NO S01-02-01-08 (ASSEMBLIES - 16SQMM CU SERVICE TERMINATION, DOUBLE INSULATED) AND PARAMETERS NOT TO BE EXCEEDED.

| NO                | DESCRIPTION   | DRN   | DATE   | CKD  | APPD |
|-------------------|---|-------|--------|------|------|
| 7                 | AMEND NOTE 5.   | C.C.C | JAN'22 | B.V. | B.C. |
| 6                 | UPDATED PWC DWG FRAME & AMENDED STOCK CODE TO ITEM NUMBER | C.C.  | MAR'19 | B.V. | B.V. |
| 5                 | USE CRITERIA UPDATED                                      | A.T.  | APR'15 | B.C. | B.C. |
| 4                 | ITEM 2 ADDED  | J.C.  | MAY'10 | A.T. | S.C. |
| 3                 | REDRAWN IN 3D   | J.C.  | APR'09 | A.T. | S.C. |
| <b>AMENDMENTS</b> |   |       |        |      |      |



| DES                           |          | POWER STANDARD DRAWING              |                             |
|-------------------------------|----------|-------------------------------------|-----------------------------|
| DES                           | A BUTLER | LINE HARDWARE                       |                             |
| DRN                           | gmck     | LV SERVICE CLAMP                    |                             |
| CKD                           | N.STUBBS | STRAIN                              |                             |
| APPD                          | B.T.KENT |                                     |                             |
| SCALE                         | NO SCALE |                                     |                             |
| ISSUED                        | DEC'92   | A3                                  | DRAWING NUMBER S01-01-04-28 |
| ALL DIM. IN                   | mm       |                                     |                             |
| DRAFTING STANDARD TO A.S.1100 |          | CAD PRODUCT - DO NOT AMEND MANUALLY |                             |

