

# Register of completed embedded generation projects greater than 200kW

2026



# Contents

---

Version history	2
1. Introduction	3
2. Purpose of register	3
3. Details included in the register	3
4. Project register	4
5. Single line diagram	20

# Version history

Version	EDMS reference	Date	Comments
1.0	D2019/538917	31/12/2019	Initial version
2.0	D2022/073570	18/02/2022	2020 Version
3.0	D2022/073572	21/02/2022	2021 Version
4.0	D2022/515243	12/12/2022	2022 Version
5.0	D2023/272762	5/7/2023	2023 Version
6.0	D2024/311153	16/8/2024	2024 Version
7.0	D2026/139947	13/05/2026	2026 Version

## Disclaimer

This document has been compiled based on the best information available to Power and Water Corporation (Power and Water) at the time of drafting, and the information published in this document should not be relied upon without consultation with Power and Water.

# 1. Introduction

This register of completed embedded generation projects has been developed to provide information on projects that have been successfully connected<sup>1</sup> to Power and Water Corporation's (Power and Water) distribution network.

## 2. Purpose of register

It is a requirement under Chapters 5 (Clause 5.18A.2) and 5A of the Northern Territory National Electricity Rules (NT NER) that Power and Water publish a register of completed embedded generation projects (i.e. for systems with a generating capacity greater than 200kW).

For projects greater than 2MW, this register:

- includes details of all embedded generation projects completed within the preceding five year period
- is to be updated annually for all completed projects in the 5 year period preceding the review date.

For projects between 200kW and 2MW, this register:

- includes details of all embedded generation projects completed since 1 July 2019
- is to be updated annually for all completed projects in the 5 year period preceding the review date.

## 3. Details included in the register

The register of completed embedded generation projects includes, but is not limited to:

- technology of generating unit (e.g. synchronous generating unit, induction generator, photovoltaic array, etc.) and its make and model
- maximum power generation capacity of all embedded generating units comprised in the relevant generating system
- contribution to fault levels
- the size and rating of the relevant transformer
- a single line diagram of the connection arrangement
- protection systems and communication systems
- voltage control and reactive power capability
- details specific to the location of a facility connected to the network that are relevant to any of the details above.

---

<sup>1</sup> To form a physical link to or through a transmission network (including to a network connection asset or through a dedicated connection asset that is physically linked to that transmission network) or distribution network.

## 4. Project register

S. No	PWC Ref. No	Year Completed (connected)	Location	Technology of the Generating Unit(s)	Generating units Details (Make and Model)	Maximum Power generation capacity of all embedded Generating Units (kW)	Contribution to Fault Levels (kA)	Size and rating of relevant transformers (voltages & kVA)	Single Line Diagram of the connection arrangement (PDF)	Protecting System and Communication Systems	Voltage Control and Reactive power capability	Details relevant to the specific location of the facility
1	EG219	2024	East Arm/ Darwin	Solar PV array	2 x Sungrow SG110CX Trina Vertex - TSM-DE18M-500 504 PV Panels	220	4.59	DT-3337/11KV, 315kVA	SLD-1	<ul style="list-style-type: none"> <li>As per Technical specification 2024.</li> </ul>	<ul style="list-style-type: none"> <li>No additional requirements required apart from Negotiation technical specification greater than 30kVA and less than equal to 2MVA.</li> </ul>	System is installed on the Large Commercial food site.

S. No	PWC Ref. No	Year Completed (connected)	Location	Technology of the Generating Unit(s)	Generating units Details (Make and Model)	Maximum Power generation capacity of all embedded Generating Units (kW)	Contribution to Fault Levels (kA)	Size and rating of relevant transformers (voltages & kVA)	Single Line Diagram of the connection arrangement (PDF)	Protecting System and Communication Systems	Voltage Control and Reactive power capability	Details relevant to the specific location of the facility
2	LEG1	2020	Katherine	Solar PV Array and BESS	RSM 144-6-340P/5BB 1500 Solar PV Panel 9 x SMA Sunny Central (SC)3000-EV - Inverter 6 x 1.053MVA GPTech BESS (3MWD3-V450 BESS)	25000+6318	9.4	3 x 22/0.665 kV, 6MVA	SLD -2	<ul style="list-style-type: none"> <li>• Anti-Islanding, Inter-tripping, synch check, differential protection scheme between KSPS and KZS.</li> <li>• Local protection and control operation of KSPS.</li> <li>• SCADA link.</li> </ul>	<ul style="list-style-type: none"> <li>• The default voltage control mode is droop control with reference voltage of 1.0pu and 4.0% droop on 10.8Mvar base.</li> <li>• The generating system, while not supplying or absorbing reactive power under an ancillary services agreement will draw electricity with a power factor in the range 0.9 lead to 0.9 lag.</li> </ul>	Katherine Solar Power Station (KSPS) is a solar generating plant near Katherine Zone Substation in Northern Territory.

S. No	PWC Ref. No	Year Completed (connected)	Location	Technology of the Generating Unit(s)	Generating units Details (Make and Model)	Maximum Power generation capacity of all embedded Generating Units (kW)	Contribution to Fault Levels (kA)	Size and rating of relevant transformers (voltages & kVA)	Single Line Diagram of the connection arrangement (PDF)	Protecting System and Communication Systems	Voltage Control and Reactive power capability	Details relevant to the specific location of the facility
3	EG225	2021	Humpty Doo	Solar PV Array	637 kWp solar array and 490 kVA inverter bank	600	N/A	N/A	SLD -1	<ul style="list-style-type: none"> <li>• Anti-islanding Auto-Synchronising Reconnection Time Overcurrent protection Under voltage Trip Pick Up Over voltage Trip Pick Up Under Frequency Trip Pick Up Over Frequency Trip Pick Up System Ramp Up Rate System Ramp Down Rate</li> <li>• The EG User is to provide Power and Water with aggregated generation information in the form specified by Power and Water in order to monitor the operation of the generating system and for the EG User to demonstrate compliance with the ramp rate control requirement.</li> </ul>	<ul style="list-style-type: none"> <li>• The EG User must maintain the power factor presented to the network between 0.9 and 1.0 (lagging) at all times.</li> </ul>	1105 ANZAC Parade, Middle Point 0836

S. No	PWC Ref. No	Year Completed (connected)	Location	Technology of the Generating Unit(s)	Generating units Details (Make and Model)	Maximum Power generation capacity of all embedded Generating Units (kW)	Contribution to Fault Levels (kA)	Size and rating of relevant transformers (voltages & kVA)	Single Line Diagram of the connection arrangement (PDF)	Protecting System and Communication Systems	Voltage Control and Reactive power capability	Details relevant to the specific location of the facility
4	LEG2	2021	Batchelor	Solar PV Array	Longi 435Wp Mono PERC HC Solar PV Panel 4 x SMA Sunny Central (SC)3000-EV - Inverter	10000	4.864	2 x 22/0.665 kV, 6MVA	SLD -2	<ul style="list-style-type: none"> <li>● Anti-Islanding, Inter-tripping, synch check, differential protection scheme between BJPS and BAZSS.</li> <li>● Local protection and control operation of BJPS.</li> <li>● SCADA link.</li> </ul>	<ul style="list-style-type: none"> <li>● The default voltage control mode is droop control with reference voltage of 1.0pu and 4.0% droop on 4.8Mvar base.</li> <li>● The generating system, while not supplying or absorbing reactive power under an ancillary services agreement will draw electricity with a power factor in the range 0.9 lead to 0.9 lag.</li> </ul>	Batchelor Solar Power Station (BJSPS) is a solar generating plant near Batchelor Zone Substation in the Northern Territory.
5	LEG3	2021	Manton	Solar PV Array	4 x SMA Sunny Central (SC)3000-EV - Inverter	10000	5.968	2 x 22/0.665 kV, 6MVA	SLD -2	<ul style="list-style-type: none"> <li>● Anti-Islanding, Inter-tripping, synch check, differential protection scheme between MTPS and MTZSS.</li> <li>● Local protection and control operation of MTPS.</li> <li>● SCADA link.</li> </ul>	<ul style="list-style-type: none"> <li>● The default voltage control mode is droop control with reference voltage of 1.0pu and 4.0% droop on 4.8Mvar base.</li> <li>● The generating system, while not supplying or absorbing reactive power under an ancillary services agreement will draw electricity with a power factor in the range 0.9 lead to 0.9 lag.</li> </ul>	Manton Solar Power Station (MTSPS) is a solar generating plant near Manton Zone Substation in the Northern Territory.

S. No	PWC Ref. No	Year Completed (connected)	Location	Technology of the Generating Unit(s)	Generating units Details (Make and Model)	Maximum Power generation capacity of all embedded Generating Units (kW)	Contribution to Fault Levels (kA)	Size and rating of relevant transformers (voltages & kVA)	Single Line Diagram of the connection arrangement (PDF)	Protecting System and Communication Systems	Voltage Control and Reactive power capability	Details relevant to the specific location of the facility
6	LEG4	2021	Batchelor	Solar PV Array	JINKO 465W Solar PV Panel 4 x SMA Sunny Central (SC)3000-EV - Inverter	10000	4.872	2 x 22/0.665 kV, 6MVA	SLD -2	<ul style="list-style-type: none"> <li>• Anti-Islanding, Inter-tripping, synch check, differential protection scheme between BSF and BAZSS.</li> <li>• Local protection and control operation of BSF.</li> <li>• SCADA link.</li> </ul>	<ul style="list-style-type: none"> <li>• The default voltage control mode is droop control with reference voltage of 1.0pu and 4.0% droop on 4.8Mvar base.</li> <li>• The generating system, while not supplying or absorbing reactive power under an ancillary services agreement will draw electricity with a power factor in the range 0.9 lead to 0.9 lag</li> </ul>	Batchelor Solar Power Station (BPS Co) is a solar generating plant near Batchelor Zone Substation in the Northern Territory.

S. No	PWC Ref. No	Year Completed (connected)	Location	Technology of the Generating Unit(s)	Generating units Details (Make and Model)	Maximum Power generation capacity of all embedded Generating Units (kW)	Contribution to Fault Levels (kA)	Size and rating of relevant transformers (voltages & kVA)	Single Line Diagram of the connection arrangement (PDF)	Protecting System and Communication Systems	Voltage Control and Reactive power capability	Details relevant to the specific location of the facility
7	LEG5	2021	Hudson Creek	Thermal generation power station	Caterpillar - 5 x G3520H Generating Units (GU).	12000	29.97	2 x 66/11kV, 15/20 MVA	SLD -2	<ul style="list-style-type: none"> <li>• Control and monitoring of the generator connection circuit breaker and isolators.</li> <li>• Tripping the generator connection due to overcurrent, line differential, under voltage and ground fault protections.</li> <li>• Check synchronisation.</li> <li>• Inter-trips.</li> <li>• additional overvoltage and frequency protection function in relays.</li> <li>• SCADA links.</li> </ul>	<ul style="list-style-type: none"> <li>• PWC will send a DNP3 pulse specific to each mode. These pulses will be translated at the power station into an integer register for processing by the PLC, as follows 0: Voltage control mode. 1: Reactive power control mode. 2: pf control mode Reactive Power: -4.75 MVar to 4.75 MVar -0.93 pu (absorbing) to 1.0 pu to 0.93 pu (exporting).</li> </ul>	Hudson Creek Power Station (HCPS)) is a gas generator plant near Hudson Creek Terminal Station in the Northern Territory.

S. No	PWC Ref. No	Year Completed (connected)	Location	Technology of the Generating Unit(s)	Generating units Details (Make and Model)	Maximum Power generation capacity of all embedded Generating Units (kW)	Contribution to Fault Levels (kA)	Size and rating of relevant transformers (voltages & kVA)	Single Line Diagram of the connection arrangement (PDF)	Protecting System and Communication Systems	Voltage Control and Reactive power capability	Details relevant to the specific location of the facility
8	LEG6	2021	Robertson Barracks, Darwin	Solar PV Array and BESS	<p>Solar System A 2 x 2.75MVA SMA Sunny Central 2750-EV</p> <p>System B 1 x 2.75MVA SMA Sunny Central 2750-EV</p> <p>System C 1 x 2.75MVA SMA Sunny Central 2750-EV</p> <p>BESS Pack:  <ul style="list-style-type: none"> <li>System A: 16X57.14Kwh BOL Samsung 198S P3 Racks.</li> <li>System B: 10X57.14Kwh BOL Samsung 198S P3 Racks.</li> <li>System C: 12X57.14Kwh BOL Samsung 198S P3 Racks.</li> </ul> </p> <p>Battery Inverter  <ul style="list-style-type: none"> <li>System A- 15x87.67kVAABB PCS100 D-Type</li> <li>System B - 8 x87.625kVA ABB PCS100 D-Type</li> </ul> </p>	10000	<p>System A - 0.42 kA</p> <p>System B - 0.22 kA</p> <p>System C - 0.22 kA</p>	<p>System A 1 x BESS, 1.5 MVA, 11/0.375kV, YNd1 coupling tx 2 x PV inverter 2.75MVA, 11/0.385kV, Dy11, ONAN tx</p> <p>System B 1 x BESS, 1.2 MVA, 11/0.375kV, YNd1 coupling tx 1 x PV inverter 2.75MVA, 11/0.6kV, Dy11, ONAN tx</p> <p>System C 1 x BESS, 1.2 MVA, 11/0.375kV, YNd1 coupling tx 1 x PV inverter 2.75MVA, 11/0.6kV, Dy11, ONAN tx</p>	SLD -2	<ul style="list-style-type: none"> <li>DNP3 SCADA interface standard.</li> </ul>	<ul style="list-style-type: none"> <li>System A <math>\pm 1.975</math>MVAr (Pf. 0.9 lead to 0.9 lag)</li> <li>System B : <math>\pm 0.9875</math> MVAr (Pf. 0.9 lead to 0.9 lag)</li> <li>System C. <math>\pm 0.9875</math> MVAr ((Pf. 0.9 lead to 0.9 lag))</li> </ul>	Robertson Barracks-Northern Territory

S. No	PWC Ref. No	Year Completed (connected)	Location	Technology of the Generating Unit(s)	Generating units Details (Make and Model)	Maximum Power generation capacity of all embedded Generating Units (kW)	Contribution to Fault Levels (kA)	Size and rating of relevant transformers (voltages & kVA)	Single Line Diagram of the connection arrangement (PDF)	Protecting System and Communication Systems	Voltage Control and Reactive power capability	Details relevant to the specific location of the facility
					<ul style="list-style-type: none"> <li>System C - 8 x87.625kVA ABB PCS100 O-Type.</li> </ul>							
9	LEG7	2021	RAAF Darwin	Solar PV Array and BESS	Solar <ul style="list-style-type: none"> <li>2 x 2200kVA SMA Sunny Central MPS BESS Pack</li> <li>12 x56.5kWH Samsung 198S P3 Racks</li> </ul> Battery Inverter <ul style="list-style-type: none"> <li>10x87.7kVA ABB PCS100 D-Type</li> </ul>	3200	1.76kA	1 x BESS, 1.2MVA, 11/0.375kV, YNd11 coupling tx 2 x PV inverter 2MVA, 11/0.385kV, Dy11, ONAN tx	SLD -2	<ul style="list-style-type: none"> <li>DNP3 SCADA interface standard.</li> </ul>	<ul style="list-style-type: none"> <li>± 1.264MVar Pf. 0.9 lead to 0.9 lag</li> </ul>	RAAF Darwin-Northern Territory
10	EG650	2023	Leanyer	Solar PV Array	[250kW DC/225kVA AC] <ul style="list-style-type: none"> <li>736 x JAM6(L) 340W</li> <li>9 x SE25K-AUS</li> </ul>	225	4.65	11/0.4kV, 1MVA	SLD-1	<ul style="list-style-type: none"> <li>Inverter-integrated anti-islanding.</li> <li>Generator Protection Relay.</li> </ul>	<ul style="list-style-type: none"> <li>Volt_VAr.</li> <li>No reactive power control.</li> </ul>	Multiple systems installed by multiple businesses on the Hibiscus Shopping Centre roofs, Leanyer

S. No	PWC Ref. No	Year Completed (connected)	Location	Technology of the Generating Unit(s)	Generating units Details (Make and Model)	Maximum Power generation capacity of all embedded Generating Units (kW)	Contribution to Fault Levels (kA)	Size and rating of relevant transformers (voltages & kVA)	Single Line Diagram of the connection arrangement (PDF)	Protecting System and Communication Systems	Voltage Control and Reactive power capability	Details relevant to the specific location of the facility
11	EG699	2022	Palmerston	Solar PV Array	<p>400kW of PV</p> <ul style="list-style-type: none"> <li>• 905 x JinkO JKM440M-6H14 440W</li> </ul> <p>350kVA of Inverters</p> <ul style="list-style-type: none"> <li>• 7 x Fronius Tauro Eco 50-3-D 50kW</li> </ul>	350	21.35	11/0.4kV, 750kVA	SLD-1	<ul style="list-style-type: none"> <li>• Inverter-integrated anti-islanding.</li> <li>• Generator Protection Relay.</li> </ul>	<ul style="list-style-type: none"> <li>• No voltage management.</li> <li>• Constant PF 0.98 lagging.</li> </ul>	Large generating systems on the Palmerston Shopping Centre roof
12	EG146	2023	Alice Springs	Solar PV Array and BESS	<p>Research PV Systems</p> <ul style="list-style-type: none"> <li>• 263kW of various PV modules</li> </ul> <p>BESS</p> <ul style="list-style-type: none"> <li>• mtu EnergyPack QS/6 300kVA/356kWh</li> </ul>	263+300	14.54	<p>PV: 22/0.4kV, 315kVA</p> <p>BESS: 22/0.4kV, 500kVA</p>	SLD-2	<ul style="list-style-type: none"> <li>• Inverter-integrated anti-islanding.</li> <li>• Generator Protection Relay.</li> <li>• High-speed data recorder linked to System Control.</li> <li>• DER Control Device.</li> </ul>	<p>PV</p> <ul style="list-style-type: none"> <li>• Constant PF 0.98 lagging.</li> </ul> <p>BESS</p> <ul style="list-style-type: none"> <li>• The default voltage control mode is droop control with varying characteristics as research for BESS C-FCAS support.</li> <li>• The generating system, while not supplying or absorbing reactive power under an ancillary services agreement will draw electricity with a power factor in the range 0.9 lead to 0.9 lag.</li> </ul>	DKA Solar Research Facility plus BESS supplying FCAS behind separate transformers

S. No	PWC Ref. No	Year Completed (connected)	Location	Technology of the Generating Unit(s)	Generating units Details (Make and Model)	Maximum Power generation capacity of all embedded Generating Units (kW)	Contribution to Fault Levels (kA)	Size and rating of relevant transformers (voltages & kVA)	Single Line Diagram of the connection arrangement (PDF)	Protecting System and Communication Systems	Voltage Control and Reactive power capability	Details relevant to the specific location of the facility
13	EG179	2020	Alice Springs	Solar PV Array	345kW of PV • 1123 x WINAICO WST310P6 310W 350kVA of Inverters • 7 x Fronius Tauro Eco 50-3-D 50kW	350	NR	11/0.4kV, 750kVA	SLD-1	<ul style="list-style-type: none"> <li>• Inverter-integrated anti-islanding.</li> <li>• Generator Protection Relay.</li> </ul>	<ul style="list-style-type: none"> <li>• Volt_VAr.</li> <li>• No reactive power control.</li> </ul>	Large generating system on roof of the Central Land Council building in Alice Springs. Replacement of old broken system.
14	EG183	2021	Alice Springs	Solar PV Array	350kW of PV 300kVA of Inverters	300	6.75	2 x 22/0.4kV, 1MVA	SLD-2	<ul style="list-style-type: none"> <li>• Inverter-integrated anti-islanding.</li> <li>• Generator Protection Relay.</li> </ul>	<ul style="list-style-type: none"> <li>• Volt_VAr</li> <li>• Power factor correction unit</li> </ul>	Large generating system with backup generator at the Roe Creek borefields
15	EG857	2017	Palmerston	Solar PV Array	478.32kW of PV 450kVA of Inverters	450	NR	11/0.4kV, 1MVA	SLD-1	<ul style="list-style-type: none"> <li>• Inverter-integrated anti-islanding.</li> <li>• Generator Protection Relay.</li> </ul>	<ul style="list-style-type: none"> <li>• No voltage management.</li> <li>• Constant PF 0.98 lagging.</li> </ul>	Large generating systems on the Oasis Shopping Centre roof, Palmerston
16	EG911	2019	Alice Springs	Solar PV Array	309.69kW of PV 300kVA of Inverters	300	NR	22/0.4kV, 1MVA	SLD-1	<ul style="list-style-type: none"> <li>• Inverter-integrated anti-islanding.</li> <li>• Generator Protection Relay.</li> </ul>	<ul style="list-style-type: none"> <li>• No voltage management.</li> <li>• Constant PF 0.98 lagging.</li> </ul>	Large generating system on shop roof, Alice Springs

S. No	PWC Ref. No	Year Completed (connected)	Location	Technology of the Generating Unit(s)	Generating units Details (Make and Model)	Maximum Power generation capacity of all embedded Generating Units (kW)	Contribution to Fault Levels (kA)	Size and rating of relevant transformers (voltages & kVA)	Single Line Diagram of the connection arrangement (PDF)	Protecting System and Communication Systems	Voltage Control and Reactive power capability	Details relevant to the specific location of the facility
17	EG756	2017	Bakewell	Solar PV Array	389.76kW of PV 360kVA of Inverters	360	NR	11/0.4kV, 100kVA	SLD-1	<ul style="list-style-type: none"> <li>• Inverter-integrated anti-islanding.</li> <li>• Generator Protection Relay.</li> </ul>	<ul style="list-style-type: none"> <li>• No voltage management.</li> <li>• Constant PF 0.98 lagging.</li> </ul>	Large generating system on shop roof, Bakewell, Palmerston
18	EG831	2015	Karama	Solar PV Array	297.44kw of PV 303.6kVA of Inverters	300	NR	11/0.4kV, 1MVA	SLD-1	<ul style="list-style-type: none"> <li>• Inverter-integrated anti-islanding.</li> <li>• Generator Protection Relay.</li> </ul>	<ul style="list-style-type: none"> <li>• No voltage management.</li> <li>• Constant PF 0.98 lagging.</li> </ul>	Large generating system on shop roof, Karama
19	EG585	2017	Coolalinga	Solar PV Array	297.86kw of PV • 1124 x QCELLS Q.PRO-G3 265 297kVA of Inverters • 11 x ABB TRIO-27 6-TL	300	NR	22/0.4kV, 750kVA	SLD-1	<ul style="list-style-type: none"> <li>• Inverter-integrated anti-islanding.</li> <li>• Generator Protection Relay.</li> </ul>	<ul style="list-style-type: none"> <li>• No voltage management.</li> <li>• Constant PF 0.98 lagging.</li> </ul>	Large generating system on shop and carpark roof, Coolalinga

S. No	PWC Ref. No	Year Completed (connected)	Location	Technology of the Generating Unit(s)	Generating units Details (Make and Model)	Maximum Power generation capacity of all embedded Generating Units (kW)	Contribution to Fault Levels (kA)	Size and rating of relevant transformers (voltages & kVA)	Single Line Diagram of the connection arrangement (PDF)	Protecting System and Communication Systems	Voltage Control and Reactive power capability	Details relevant to the specific location of the facility
20	EG544	2016	Woolner	Solar PV Array	<p>[System 1]</p> <p>400kW of PV</p> <ul style="list-style-type: none"> <li>• 1536 x TRINA SOLAR 260W</li> </ul> <p>400kVA of Inverters</p> <ul style="list-style-type: none"> <li>• 16 x SMA STP 25000TL</li> </ul> <p>[System 2]</p> <p>236kW of PV</p> <ul style="list-style-type: none"> <li>• 11 x ABB TRIO-27 6-TL</li> </ul> <p>236kVA of Inverters</p> <ul style="list-style-type: none"> <li>• 8 x Fronius ECO 27kW</li> <li>• Fronius SYMO 20kW</li> </ul>	636	NR	11/0.4kV, 1MVA	SLD-1	<ul style="list-style-type: none"> <li>• Inverter-integrated anti-islanding.</li> <li>• Generator Protection Relay.</li> </ul>	<ul style="list-style-type: none"> <li>• No voltage management.</li> <li>• Constant PF 0.98 lagging.</li> </ul>	Large generating system on shop roof, Woolner
21	EG654	2016	Alice Springs	Solar PV Array	<p>326kW of PV</p> <ul style="list-style-type: none"> <li>• 1126 x JA Solar – JAM6 60 290 PR</li> </ul> <p>285kVA of Inverters</p> <ul style="list-style-type: none"> <li>• 16 x Fronius SYMO</li> </ul>	285	NR	11/0.4kV, 1MVA	SLD-1	<ul style="list-style-type: none"> <li>• Inverter-integrated anti-islanding.</li> <li>• Generator Protection Relay.</li> </ul>	<ul style="list-style-type: none"> <li>• No voltage management.</li> <li>• Constant PF 0.98 lagging.</li> </ul>	<p>Large generating system on shop roof, Alice Springs</p> <p>Other smaller systems on same property, different connection points.</p>

S. No	PWC Ref. No	Year Completed (connected)	Location	Technology of the Generating Unit(s)	Generating units Details (Make and Model)	Maximum Power generation capacity of all embedded Generating Units (kW)	Contribution to Fault Levels (kA)	Size and rating of relevant transformers (voltages & kVA)	Single Line Diagram of the connection arrangement (PDF)	Protecting System and Communication Systems	Voltage Control and Reactive power capability	Details relevant to the specific location of the facility
22	EG541	2019	Braitling	Solar PV Array and BESS	[System 1] 100kW of PV 85kVA of Inverters [System 2] 375kW of PV 250kVA of Hybrid Inverters 250kVA BESS	350	NR	11/0.4kV, 750kVA	SLD-1	<ul style="list-style-type: none"> <li>● Inverter-integrated anti-islanding.</li> <li>● Generator Protection Relay.</li> </ul>	<ul style="list-style-type: none"> <li>● 120kVAR Power Factor Correction Unit in 5kVAR intervals.</li> <li>● No voltage management.</li> <li>● Constant PF 0.98 lagging.</li> </ul>	Large Generating System on shop roofs, Braitling. Both systems behind the same meter
23	EG878	2023	Palmerston	Solar PV Array	48 * 27kW Fronius Eco27.0.3-S 3721 x 400 W REC 400 TWIN PEAK	1488.4	NR	11/0.4kV, 1.5MVA	SLD-1	<ul style="list-style-type: none"> <li>● Inverter-integrated anti-islanding.</li> <li>● Generator Protection Relay.</li> </ul>	<ul style="list-style-type: none"> <li>● No voltage management except for over Voltage and under-Voltage trips.</li> <li>● Constant PF 0.9 lagging and supplying reactive power.</li> </ul>	Large Generating system on Rooftop of Gateway shopping centre power.
24	LEG8	2016	Darwin	Solar PV Array	23 x 60 kW SMA Sunny tri Power Inverters (1.3MW) 60*60 kVA Sunny Tri power 60-10 15000 x Hanwha Q-Cells Q.PRO G4.1 265 5750*265W Q cells	5498.75	NR	11/0.4kV	SLD-2	<ul style="list-style-type: none"> <li>● Inverter-integrated anti-islanding.</li> <li>● Generator Protection Relay.</li> </ul>	<ul style="list-style-type: none"> <li>● No voltage management except for over Voltage and under-Voltage trips.</li> <li>● Constant PF 0.98 lagging.</li> </ul>	Large Solar Farm located at 40 Henry Wrigley Drive. This farm is adjacent to Nautilus Aviation.

S. No	PWC Ref. No	Year Completed (connected)	Location	Technology of the Generating Unit(s)	Generating units Details (Make and Model)	Maximum Power generation capacity of all embedded Generating Units (kW)	Contribution to Fault Levels (kA)	Size and rating of relevant transformers (voltages & kVA)	Single Line Diagram of the connection arrangement (PDF)	Protecting System and Communication Systems	Voltage Control and Reactive power capability	Details relevant to the specific location of the facility
25	PND80003	2024	Channel Island Power Station	Solar PV Array and BESS	Grid Forming BESS 512 x 0.08002074 MVA ABB PCS100, VGM, C-Type	32600	<p>three phase fault current, 0.39 kA;</p> <p>phase to phase to ground fault current, 0.99 kA;</p> <p>phase to phase fault current, 0.39 kA;</p> <p>Single phase to ground fault current, 0.82 kA;</p> <p>for 450 ms.</p>	132/11.45kV, 48 MVA	SLD 2 – High voltage connection with low voltage generating system	<ul style="list-style-type: none"> <li>• Primary protection systems to disconnect from the power system any faulted element within the generating system</li> <li>• Protection system to disconnect plant in response to abnormal conditions arising from the power system, as outlined by the NTC</li> <li>• Protection system to disconnect its generating units promptly for conditions where the active power, reactive power or voltage at the connection point becomes unstable.</li> <li>• Inverter Frequency Protection</li> <li>• Inverter Voltage Protection</li> <li>• Breaker fail protection systems</li> <li>• Rate of Change of Frequency (RoCoF) protection relay</li> <li>• DNP3 SCADA interface standard</li> </ul>	<ul style="list-style-type: none"> <li>• The VGM is the main primary controller (inverter) of the DKBESS generating system, Reactive Capability: <math>\pm 35.00\text{MVAR}</math></li> </ul>	132kV CIPS DS-203C

S. No	PWC Ref. No	Year Completed (connected)	Location	Technology of the Generating Unit(s)	Generating units Details (Make and Model)	Maximum Power generation capacity of all embedded Generating Units (kW)	Contribution to Fault Levels (kA)	Size and rating of relevant transformers (voltages & kVA)	Single Line Diagram of the connection arrangement (PDF)	Protecting System and Communication Systems	Voltage Control and Reactive power capability	Details relevant to the specific location of the facility
										<ul style="list-style-type: none"> <li>Communications paths (with appropriate redundancy) between RME or RCE installed at any of its generating units to a communications interface at the relevant power station and in a location reasonably acceptable to the Network Operator.</li> </ul>		
26	EG310	2025	Darwin	Solar PV Array	2 x SG110CX (AS4777-2 2020) (220kVA) 516x 440W Trina Solar TSM-44ONEG9R.28	220	NR	11/0.4kV, 1MVA	SLD-1	<ul style="list-style-type: none"> <li>Inverter-integrated anti-islanding.</li> <li>Grid Protection Relay.</li> </ul>	<ul style="list-style-type: none"> <li>Volt-Var</li> <li>No reactive power control</li> </ul>	Large generating system on roof of Karama Shopping Plaza in Darwin. Added to existing 315kVA system.
27	EG274	2026	Alice Springs	Solar PV Array	Sungrow 2x CX110 110 kVA + 1x CX50 – 50 kVA 727 x Yingli 440w YL440CF48	270	NR	11/0.4kV	SLD-1	<ul style="list-style-type: none"> <li>Inverter-integrated anti-islanding.</li> <li>Grid Protection Relay.</li> </ul>	<ul style="list-style-type: none"> <li>Volt-Var</li> <li>No reactive power control</li> </ul>	Large generating system on roof of Metcash Food & Grocery Convenience Division Pty Ltd in Alice Springs. Added to existing 315kVA system.

S. No	PWC Ref. No	Year Completed (connected)	Location	Technology of the Generating Unit(s)	Generating units Details (Make and Model)	Maximum Power generation capacity of all embedded Generating Units (kW)	Contribution to Fault Levels (kA)	Size and rating of relevant transformers (voltages & kVA)	Single Line Diagram of the connection arrangement (PDF)	Protecting System and Communication Systems	Voltage Control and Reactive power capability	Details relevant to the specific location of the facility
28	EG250	2026	Darwin	Solar PV Array and BESS	1 x Sinexcel PWS1-500KTL-EX-4M (4 x 62.5kW Modules) 442 x 590 W Yingli n-type Bifacial 590W Battery Pack Make and Model: BYD Blade 1C water cooled Battery Control System Make and Model: BYD Blade BMS	325	NR	22/0.4kV, 200 kVA	SLD-1	<ul style="list-style-type: none"> <li>• Inverter-integrated anti-islanding.</li> <li>• Generator Protection Relay.</li> </ul>	<ul style="list-style-type: none"> <li>• Volt-Var</li> <li>• No reactive power control</li> </ul>	Large generating system at PRI Farming, Middle Point. Added a 250kVA system to the existing 75kVA system.
29	EG252	2026	Darwin	Solar PV Array and BESS	1 x Sinexcel PWS1-500KTL-EX-5M1 590 x 627W Yingli n-type Bifacial 590W Battery pack make and model = BYD Blade 1C water cooled Battery control system make and model = BYD Blade BMS	412.5	NR	22/0.4kV	SLD-1	<ul style="list-style-type: none"> <li>• Inverter-integrated anti-islanding.</li> <li>• Generator Protection Relay.</li> </ul>	<ul style="list-style-type: none"> <li>• Volt-Var</li> <li>• No reactive power control</li> </ul>	Large generating system at PRI Farming, Bees Creek. Added a 312.5kVA system to the existing 100kVA system.

## 5. Single Line diagram

The following single line diagrams depict typical connection arrangements for embedded generators connecting to the Power and Water distribution network.

These diagrams are used as a reference for connection arrangements listed in the register.

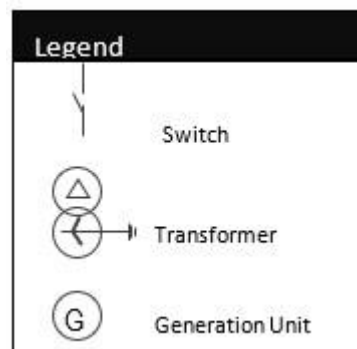

**SLD 1 – Low voltage connection with low voltage generating system (synchronous or induction machine, or inverter energy system)**

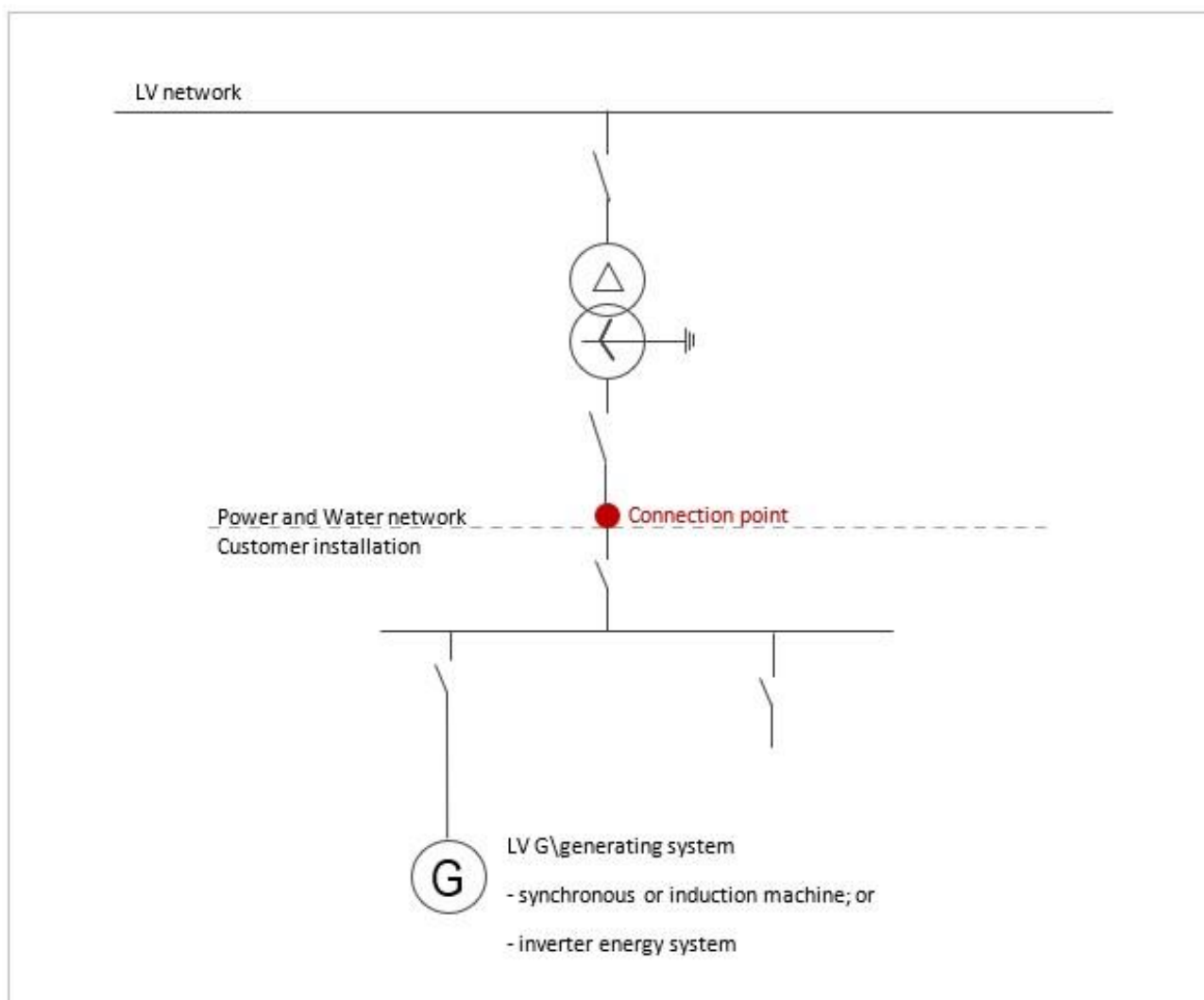

**SLD 2 – High voltage connection with low voltage generating system**  
(synchronous or induction machine, or inverter energy system)

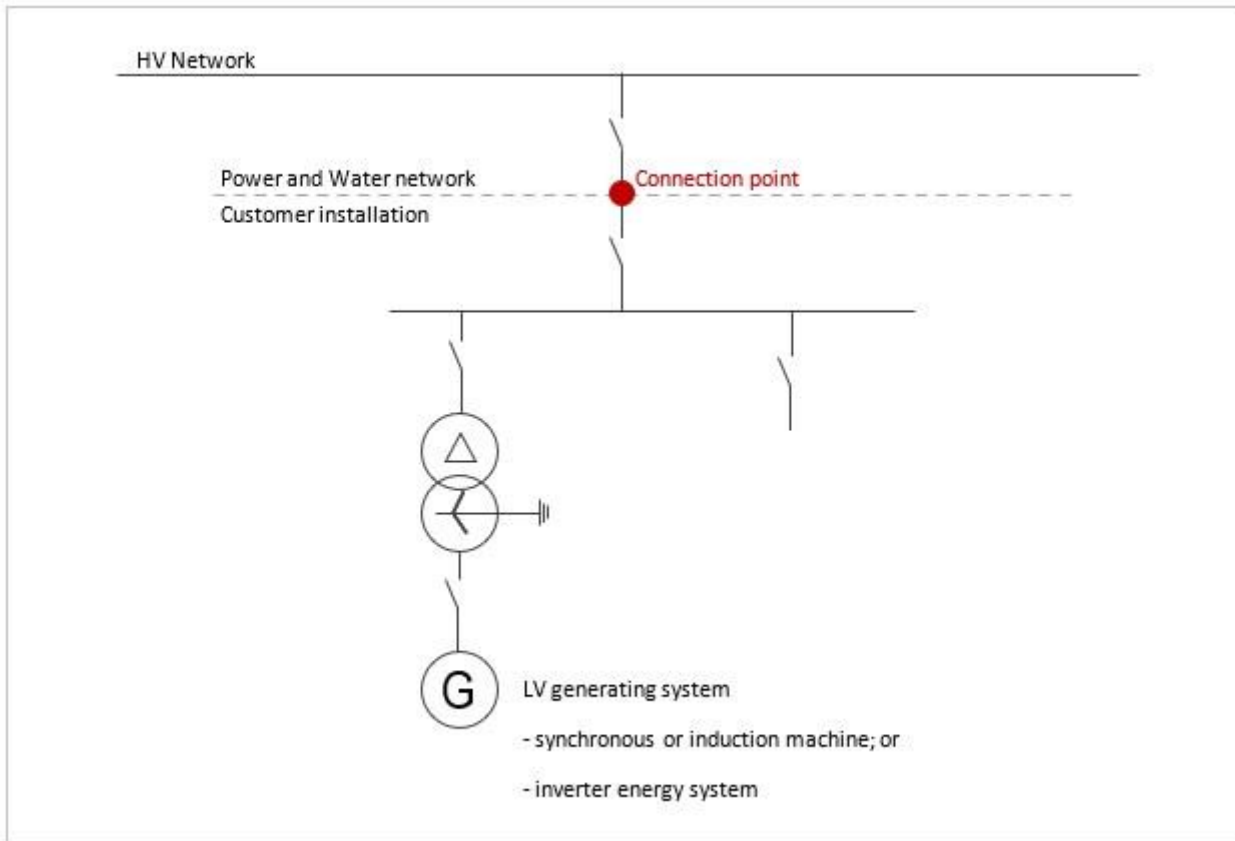

**SLD 3 – High voltage connection with high voltage generating system**  
(synchronous or induction machine)

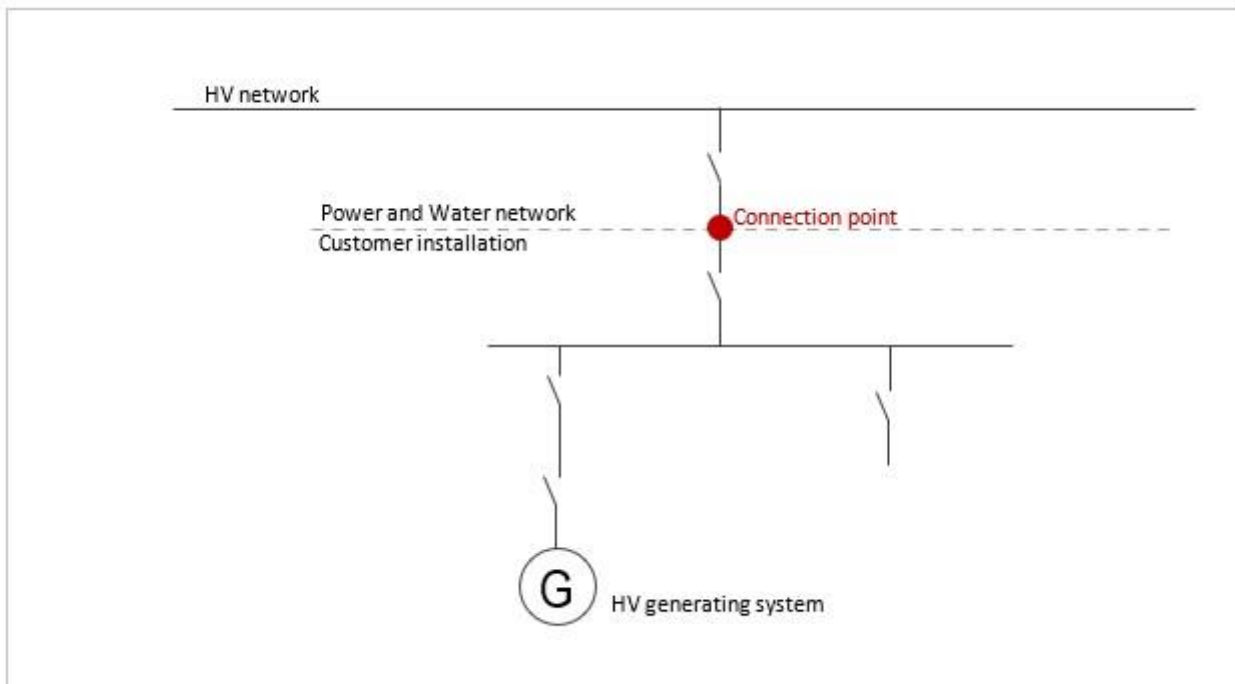

## Contact

Power and Water Corporation  
Email: [networkdevelopmentandplanning.pwc@powerwater.com.au](mailto:networkdevelopmentandplanning.pwc@powerwater.com.au)  
Phone: 1800 245 092  
[powerwater.com.au](http://powerwater.com.au)

**PowerWater** 