

FOR POTABLE WATER ONLY

THIS ASSEMBLY IS NOT TO BE USED FOR SEWERAGE INSTALLATIONS

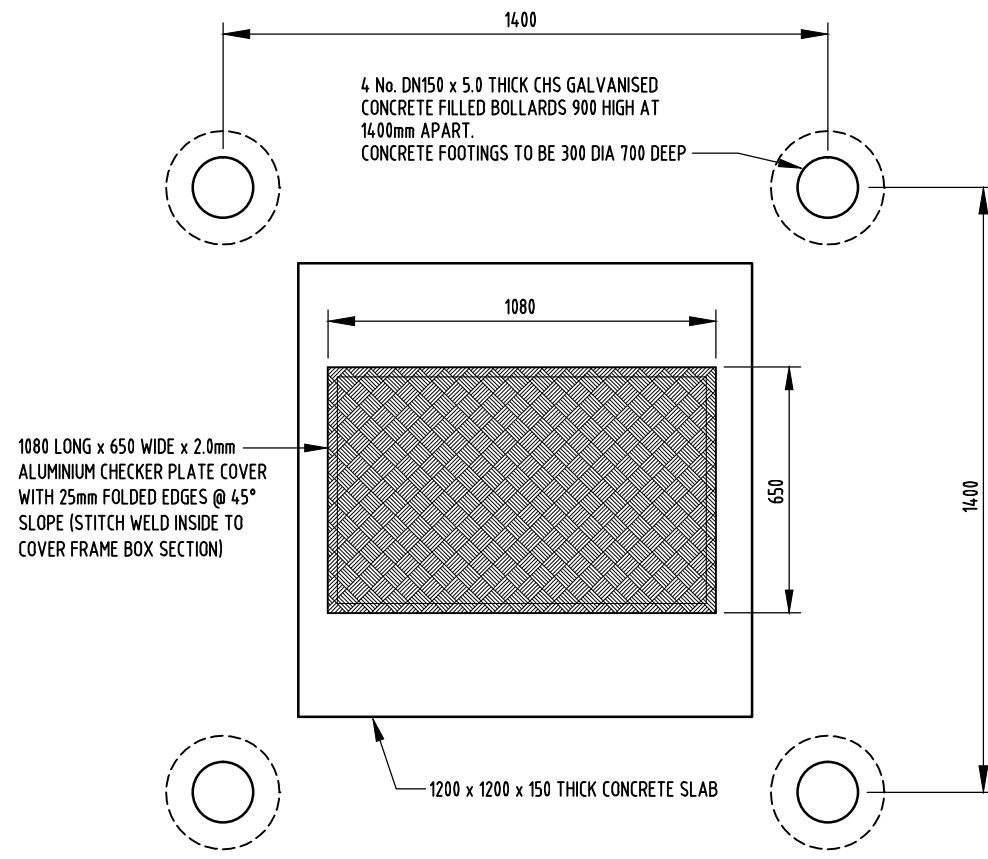

PLAN - TOP VIEW

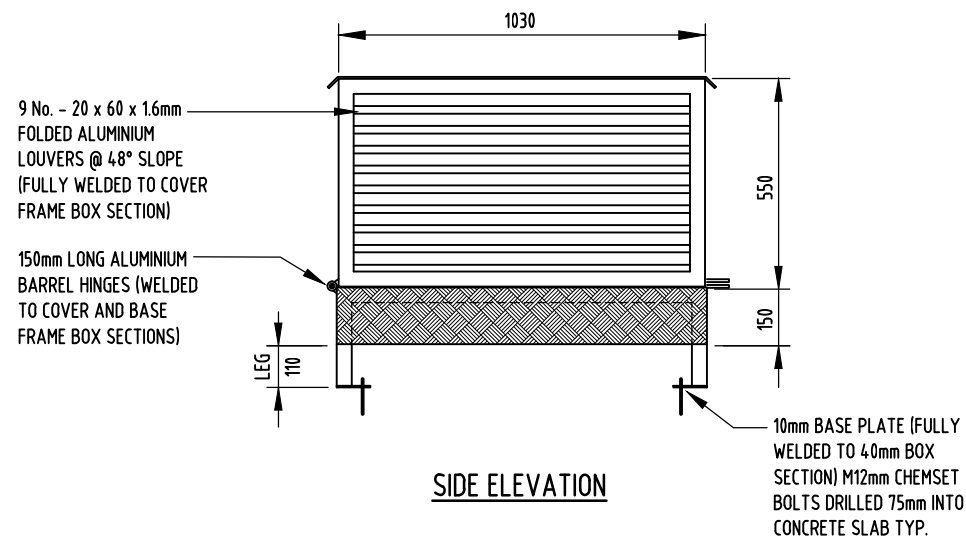

SIDE ELEVATION

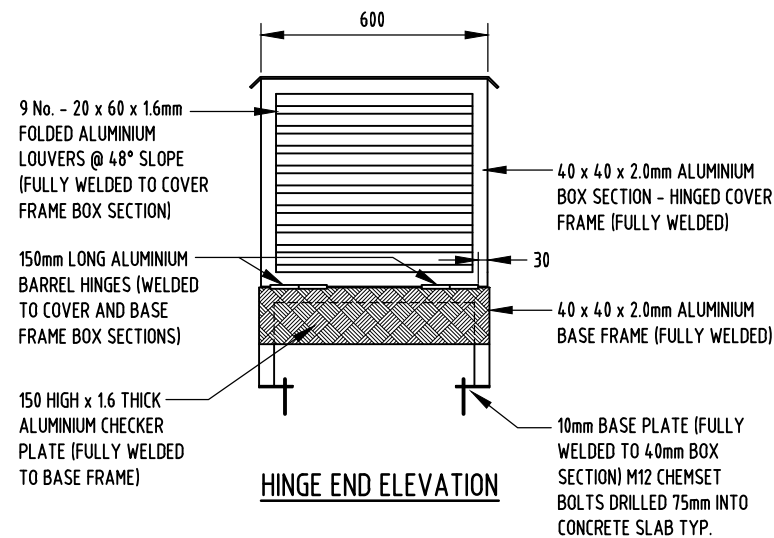

HINGE END ELEVATION

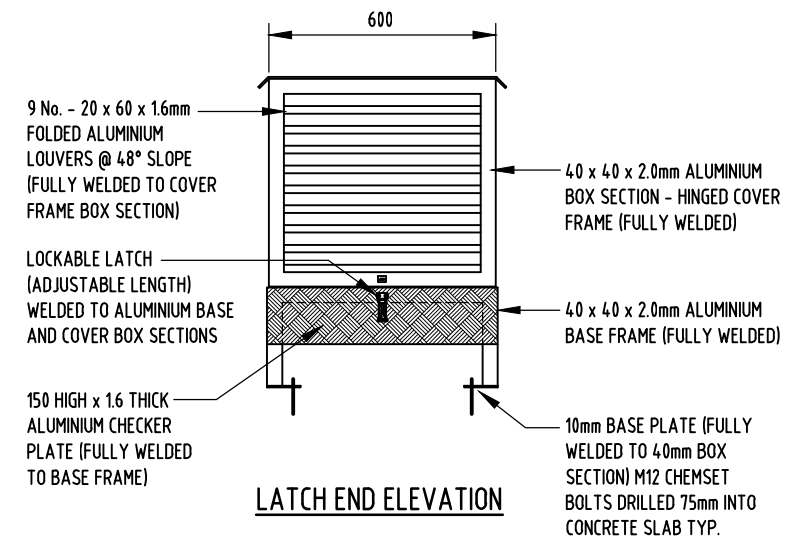

LATCH END ELEVATION

NOTES

1. ALL BRITE COVER BOX AFTER FABRICATION TO REDUCE REFLECTION FROM CAR HEAD LIGHTS.
2. REFER TO PWC STD DRG. W1-2-13B FOR AIR VALVE ASSEMBLY DETAILS.

1	NEW DRAWING AND GENERAL AMENDMENTS 2021.	PW	JUNE '21	IL	DC
NO	DESCRIPTION	DRN	DATE	CKD	APPD
	AMENDMENTS				



DES	RJ	WATER STANDARD DRAWING		
DRN	RGI	MAINLAYING		
CHK	RJ	STANDARD DN150 AIR VALVE		
APPD	JP	COVER BOX DETAILS		
SCALE	N.T.S.	A3	DRAWING NUMBER	1
ISSUED	AUG'08		W1-2-13D	
ALL DIM. IN mm				
DRAFTING STANDARD TO A.S.1100		CAD PRODUCT - DO NOT AMEND MANUALLY		