

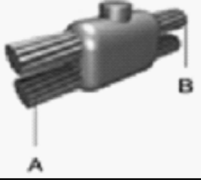



CADWELD CONNECTION TYPE	MOULD DESCRIPTION	CADWELD PLUS MOULD PART NUMBER	MOULD PWC STOCK CODE	CADWELD PLUS WELD METAL	COLOUR OF WELD METAL PACKAGING	PWC WELD METAL STOCK CODE
	PARALLEL HORIZONTAL MOULD 70/70SQMM CABLE	PTCY4Y4	503457	115PLUSF20	ORANGE	503463
	PARALLEL HORIZONTAL MOULD 70/95SQMM CABLE	PTCY5Y4	503458	150PLUSF20	DARK BLUE	503464
	PARALLEL HORIZONTAL MOULD 95/95SQMM CABLE	PTCY5Y5	503459	120PLUSF20	YELLOW	503462
	PARALLEL HORIZONTAL MOULD 70/35SQMM CABLE	PTCY4Y2	503454	90PLUSF20	GRAY	503466
	25MM X 3MM BAR TO 70SQMM CABLE	LJCCAJY4	503452	90PLUSF20	GRAY	503466
	25MM X 3MM BAR SPLICE	BBCCAJ	503451	65PLUSF20N	DARK GREEN	503465

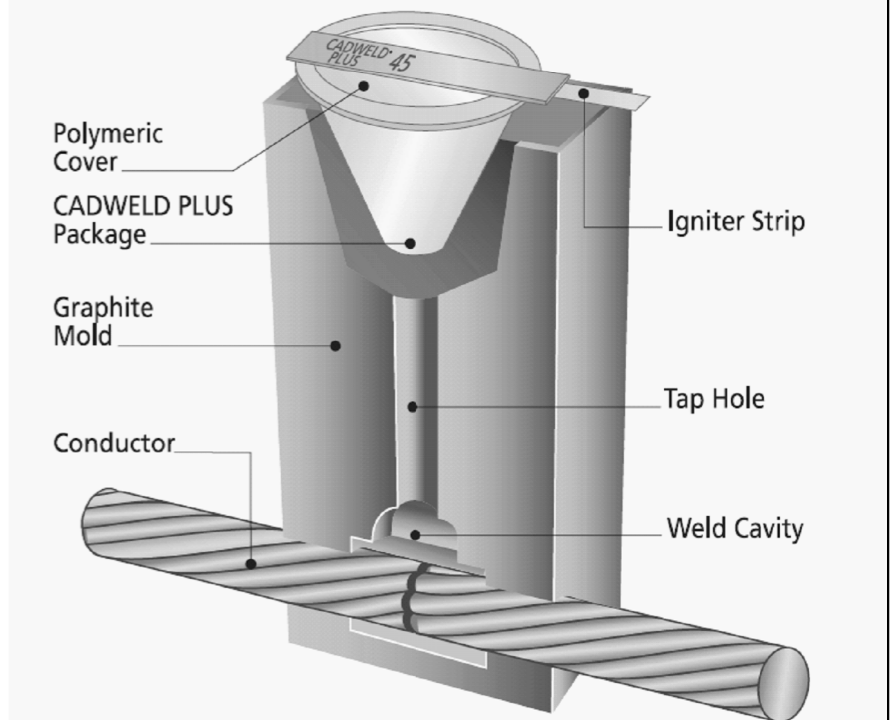

OTHER EQUIPMENT	PWC STOCK CODE
CADWELD PLUS CONTROL UNIT	503672
MOULD HANDLE CLAMP	503461
MOULD CLEANING BRUSH	503467
MOULD SEALER	503674
CADWELD CERAMIC BLANKET	503719
REPLACEMENT 4.6M CONTROL LEAD	503760

- NOTES:
1. AUTHERISATION MUST BE OBTAINED FROM SERVICE DELIVERY CO-ORDINATOR BEFORE USING CADWELD PLUS EQUIPMENT.
 2. SURROUNDING AREA AND ENVIROMENT MUST BE ASSESSED TO DETERMINE THE SUITABILITY OF USING THE CADWELD PLUS EQUIPMENT.
 3. INSTRUCTIONS FOR USE ARE CONTAINED INSIDE EQUIPMENT CARRY CASE.
 4. ONLY CADWELD PLUS EQUIPMENT SHALL BE USED.
 5. POWER AND WATER OH&S AND WORKING PROCEDURES SHALL BE FOLLOWED WHILE USING CADWELD PLUS EQUIPMENT.
 6. GRAPHITE MOLDS MUST BE COOLED DOWN BEFORE RETURNING THEM TO THE CARRY CASE.

	0	ISSUED FOR CONSTRUCTION	A. T.	MAY '16	I. B.	B. C.		DES	B. CHEUNG	POWER STANDARD DRAWING					
	NO	DESCRIPTION	DRN	DATE	CKD	APPD		DRN	A. TAYLOR	EARTHING CADWELD PLUS CONNECTIONS					
	AMENDMENTS							CKD	I. BASHIR			A3	DRAWING NUMBER S02-1-5-03		
								APPD	B. CHEUNG						DRAFTING STANDARD TO A.S.1100
							SCALE	N. T. S.							
							ISSUED	MAY '16							
							ALL DIM. IN mm								