

SWITCH PACK  
(ITEM NUMBER 285254)  
REFER TO S03-01-05-07

12m VIAC COLUMN  
(ITEM NUMBER 219055)

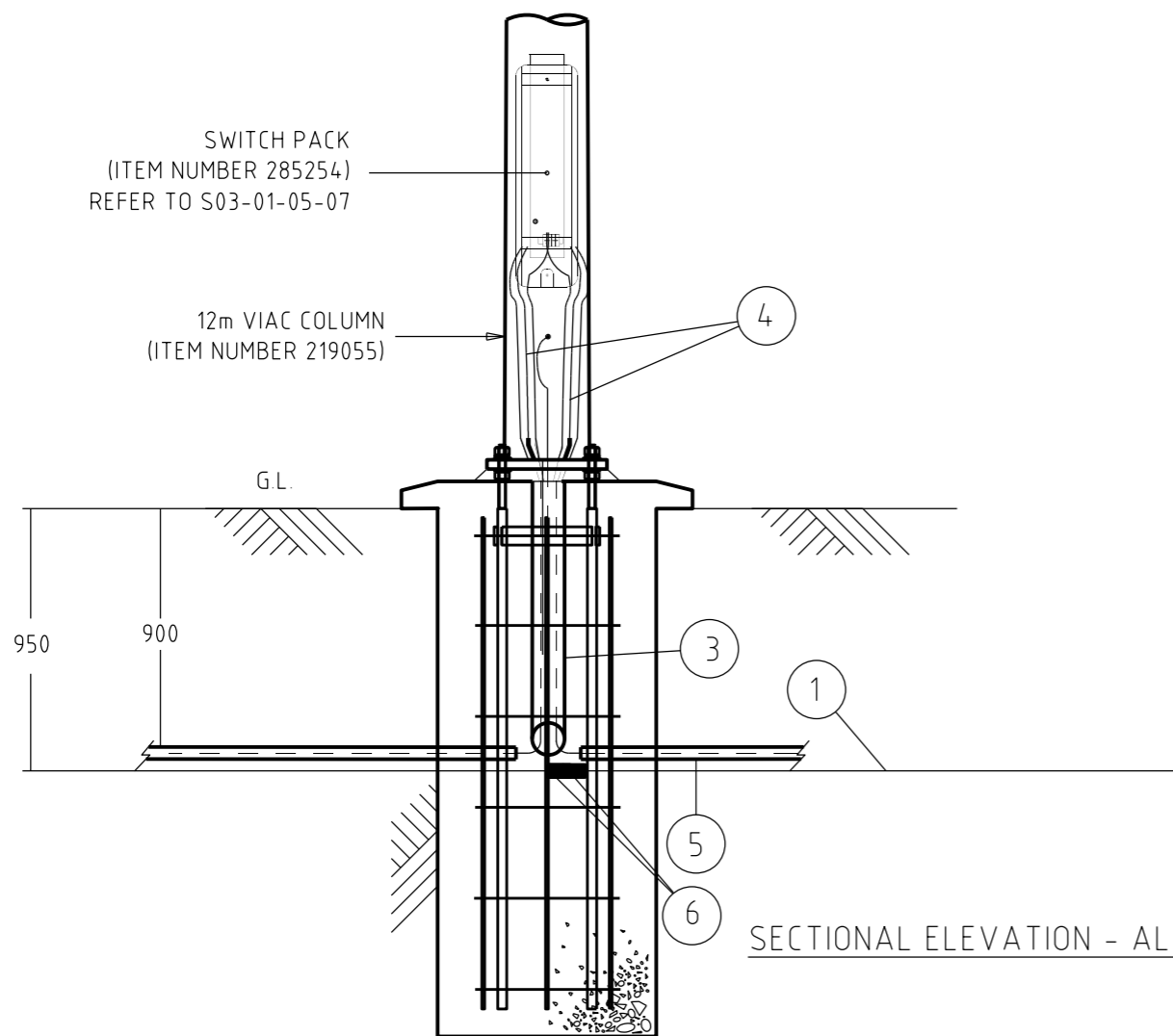

SECTIONAL ELEVATION - ALONG CABLE ROUTE

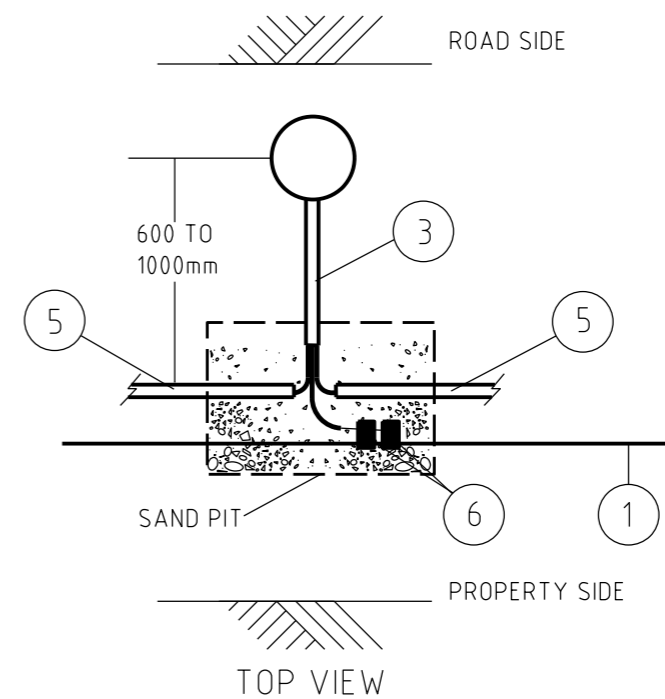

TOP VIEW

NOTES:

- CONDUITS ARE TO BE CURVED FROM THE NORMAL CABLE DEPTH (900MM) TO THE BOTTOM OF THE PIT OVER A DISTANCE OF 2500mm

REFERENCE DRAWING:

- S03-01-01-04 - COLUMN TAPERED STEEL VIAC 12M DOUBLE OUTREACH
- S03-01-02-03 - RAG BOLT REINFORCEMENT FOUNDATION ARRANGEMENT
- S03-01-05-06 - SWITCH PACK LIGHTING COLUMN INTEGRAL
- S03-01-05-07 - SWITCH PACK WIRING DIAGRAM

ITEM REF.	QTY.	DESCRIPTION	ITEM NUMBER	DRAWING REF.
6	2	35sqmm COMPRESSION CONNECTOR PROFILE 'C'	406821	S01-01-05-08
5	AR	CONDUIT - 80mm CAT 'A' PVC	3939	S02-01-09-02
4	AR	CABLE 25sqmm Cu/XLPE/NYL/MDPE BLACK	9456	S02-01-01-20
3	1	CONDUIT BEND 90 DEG. - 80mm CAT 'A' PVC	503551	S02-01-09-02
2	AR	CONDUIT - 50mm CAT 'A' PVC	3913	S02-01-09-02
1	AR	BARE CONDUCTOR - EARTHING 35sqmm	9829	S01-01-05-05

MATERIAL SCHEDULE

NO	DESCRIPTION	DRN	DATE	CKD	APPD
5	REFORMATTED TEXT AND TABLE. UPDATED ITEMS 1, 2, 3, 4, 5 & 6.	A.N.	AUG'21	A.N.	B.V.
4	TITLEBLOCK & DRAWING NUMBERS FORMATTED	K.T.	FEB'19	C.C.	C.C.
3	EXTRA COMPRESSION CLAMP ADDED	C.C.	AUG'17	I.B.	B.C.
2	UPDATE STOCK CODE, NOTES AND CONDUIT DETAILS. PIT REMOVED	K.I.	SEP'05	C.C.	C.C.
1	ITEM No'S 9, 10, 11 & 12 ADDED. CABLE ROUTE CONNECTION DETAIL ADDED	gmck	JUL'92	N.S.	B.T.K

**PowerWater**

NORTHERN TERRITORY

DES	A.TICE	POWER STANDARD DRAWING	
DRN	gmck	MISCELLANEOUS VIAC POLE AND PIT CONNECTION DETAILS	
CKD	N.STUBBS	A3	DRAWING NUMBER S03-01-06-02
APPD	B.T.KENT		
SCALE	1:20	DRAWING NUMBER S03-01-06-02	
ISSUED	DEC'91	DRAWING NUMBER S03-01-06-02	
ALL DIM. IN mm		DRAWING NUMBER S03-01-06-02	
DRAFTING STANDARD TO A.S.1100		CAD PRODUCT - DO NOT AMEND MANUALLY	

5  
AMDT