

Plan

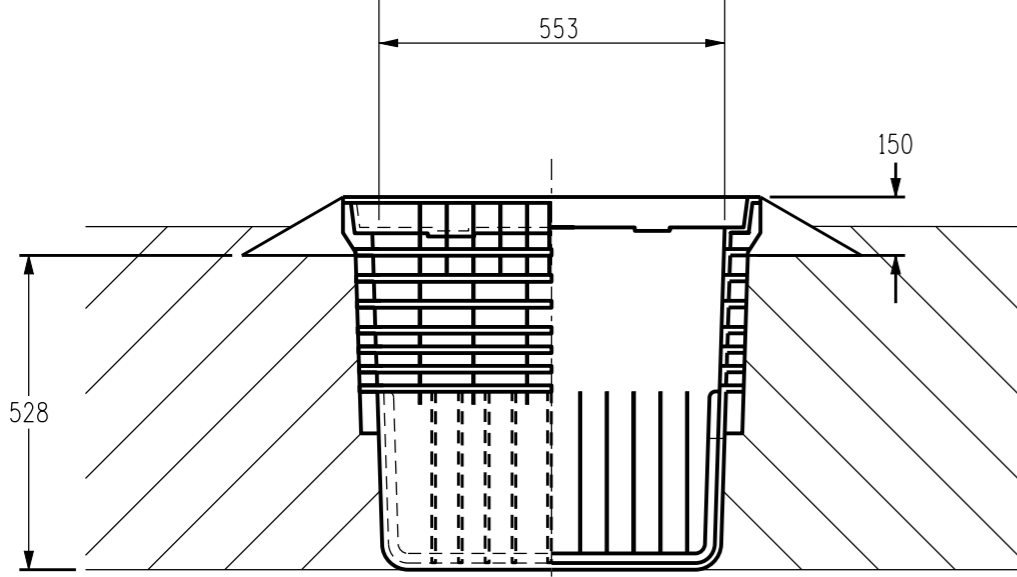

Elevation/Section

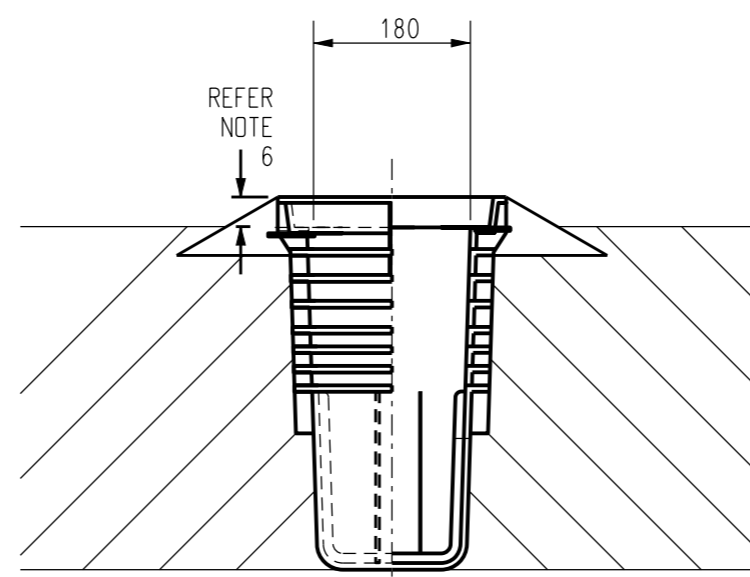

End Elevation/Section

ITEM 1 - PIT CABLE JOINTING

(STOCK CODE 247759)

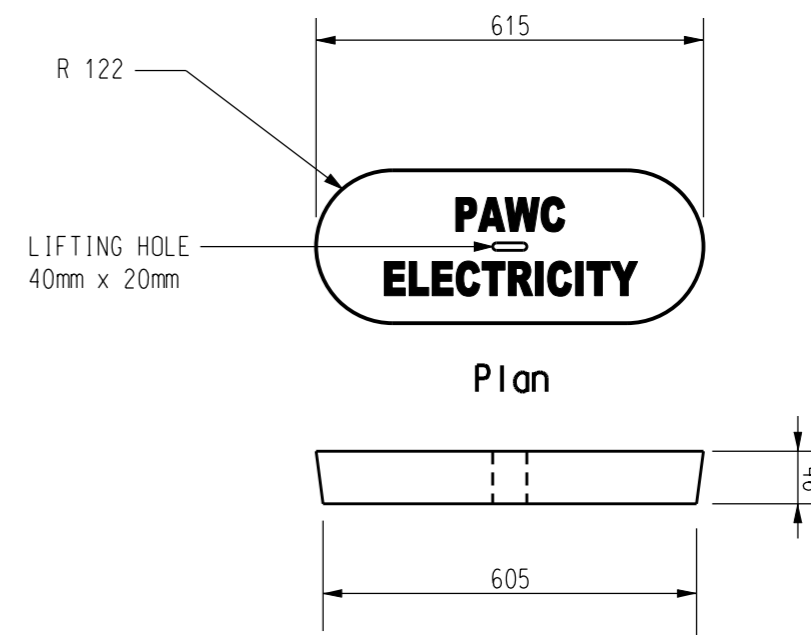

Plan

Elevation

ITEM 2 - COVER CABLE JOINTING PIT

(STOCK CODE 247767)

NOTES

1. CABLE JOINTING PIT (ITEM 1) MATERIAL TO BE HIGH DENSITY POLY-ETHYLENE.
2. CONCRETE COVER TO HAVE A MINIMUM COMPRESSIVE DESIGN STRENGTH (F' c) OF 30 MPa AT 28 DAYS.
3. ALL REINFORCEMENT, CONCRETE AND CONCRETE MATERIALS SHALL BE IN ACCORDANCE WITH AS3600.
4. ENGRAVED LETTERING IN CONCRETE COVER TO BE
- 55mm HIGH
- 6mm THICK
- 5mm DEEP
5. CONCRETE COVER TO HAVE A NON-SKID FINISH ON THE UPPER SURFACE.
6. PIT TO BE 100mm ABOVE GROUND LEVEL IF NOT LANDSCAPED, OR 25mm IF LANDSCAPED.
7. AREA AROUND LID MUST BE RIGIDLY SUPPORTED BY MIN 150mm WIDE x 150mm DEEP CONCRETE SURROUND

NO	DESCRIPTION	DRN	DATE	CKD	APPD
2	GROUND LEVEL DETAILS CHANGED	A.T.	SEP'11	B.C.	S.C.
1	CONCRETE SURROUND ADDED	J.C.	SEP'07	A.T.	A.T.
0	ISSUED FOR CONSTRUCTION	K.I.	JUL'05	C.C.	C.C.
AMENDMENTS					



DES	A.Tice	POWER STANDARD DRAWING		
DRN	gmck	MISCELLANEOUS PIT CABLE JOINTING		
CKD	N.Stubbs			
APPD	B.T.Kent			
SCALE	1:10			
ISSUED	DEC '91	A3	DRAWING NUMBER	S03-1-6-01
ALL DIM.	IN mm			
DRAFTING STANDARD TO A.S.1100		CAD PRODUCT - DO NOT AMMEND MANUALLY		AMDT